



Security Engineered Machinery Co., Inc.

**OPERATIONAL & Maintenance Manual**  
**SEM Model 1324C/3**  
**Shredder**



Rev. 1

As of January 1, 2008

Security Engineered Machinery Co., Inc

**NATIONWIDE SERVICE**

Phone Toll Free 1(800)225-9293

Email: [Service@SEMSHRED.com](mailto:Service@SEMSHRED.com)

Fax: (508)366-6814

Website: [WWW.SEMSHRED.com](http://WWW.SEMSHRED.com)

---

Safety Precautions.....2-7

Installation.....8

Operation.....10-12

Maintenance.....13

Troubleshooting.....14-17

Accessories.....18

Technical Information.....19

Product Information.....20

Parts List (Back of Manual)

For NATIONWIDE SERVICE Call 1(800)225-9293

## **SAFETY PRECAUTIONS**



- D** Bitte lesen Sie vor Inbetriebnahme der Maschine unbedingt diese Betriebsanleitung und beachten Sie die Sicherheitshinweise. Die Betriebsanleitung muss jederzeit verfügbar sein.
- GB** Please read these operating instructions before putting the machine into operation and observe the safety precautions. The operating Instructions must always be available.
- F** Nous vous prions de lire attentivement le mode d'emploi avant d'utiliser la machine, et attirons votre attention sur les consignes de Sécurité. Les instructions d'utilisation et les consignes de sécurité Doivent toujours être disponibles. Les instructions d'utilisation et les consi.
- NL** Leest u voor de ingebruik name van het apparaat a.u.b. deze Gebruiksaanwijzing goed door en neemt u de veiligheidsinstructies N acht. De gebruiksaanwijzing en de veiligheids-voorschriften moeten altijd binnen handbereik zijn.
- I** Per favore legga questo manuale di istruzione prima di mettere in funzione il distruggidocumenti e osservi le regole di sicurezza. Le Istruzioni d'uso devono essere sempre disponibili.
- E** Le recomendamos lea las instrucciones antes de poner en funcionamiento esta máquina y cumpla las normas de seguridad. Las instrucciones de servicio y seguridad deben estar siempre disponibles.
- S** Läs igenom denna bruksanvisning innan ni startar maskinen. Var noga med säkerhetsföreskrifterna. Instruktionsmanualen måste alltid finnas tillgänglig.
- FIN** Lue nämä käyttö-ohjeet läpi ennenkui käynnistät laitteen ! Noudata Turvaohjeita. Käyttöohjeiden on oltava aina saatavilla.
- N** Lees gjennom denne bruksanvisningen før De tar I bruk maskinen Vær oppmerksom på sikkerhetsforskriftene. Operatørmanualen må alltid være tilgjengelig.
- PL** Proszę uważnie przeczytać instrukcję obsługi przed uruchomieniem urządzenia I stosować się do przepisów bezpieczeństwa. Instrukcje obsługi muszą być zawsze dostępne.
- RUS** Пожалуйста, процитайте инструкцию по эксплуатации перед Установкция по эксплуатации должна находиться в оступном для Пользователя месте.
- H** A gép üzembe helyezése előtt figyelmesen olvassa ela kezelési utaitást És tartsa be a buztonsági eloirásokat. Kezelési utasításnak mindig Elérhetonek kell lennie.
- TR** Lütfen makineyi çalıştırımadan once bu kullanma talimatlarini dikkatli Bir şekilde okuyunuz ve belirtilen güvvenlik önlemlerine uyunuz. Kullanma Talimatları her zaman kullanma hazır olmalıdır.
- DK** Før installation af maskinen bedes De venligst læse brugervejledningen Brugervejledningen og væse opmærksom på sikkerhedsanvisningerne. Brugervejledningen skal altid være tilgængelig.

**For NATIONWIDE SERVICE Call 1(800)225-9293**



- CZ** Prosím přečtěte si instrukce k obsluze a dodržujte bezpečnostní Upozornění. Návod k obsluze musí být vždy dostupný.
- P** Por favor leiam o manual de instruções antes de colocar a máquina em Operação e vejam as precauções de segurança. As instruções de operação deverão estar sempre disponíveis.
- GR** ΠΑΡΑΚΑΛΩ ΔΙΑΒΑΣΤΕ ΤΙΣ ΟΔΗΓΙΕΣ ΧΡΗΣΕΩΣ ΚΑΙ ΤΙΣ ΠΡΟΦΥΛΑΞΕΙΣ ΑΣΦΑΛΕΙΑΣ ΠΡΙΝ ΒΑΕΤΕ ΤΟ ΜΗΧΑΝΗΜΑ ΣΕ ΛΕΙΤΟΥΡΓΙΑ. ΟΙ ΟΔΗΓΙΕΣ ΧΡΗΣΗΣ ΠΡΕΠΕΙ ΝΑ ΕΙΝΑΙ ΠΑΝΤΑ ΔΙΑΘΕΣΙΜΕΣ.



- D** Keine Bedienung Durch Kinder!
- GB** Children must not operate the machine!
- F** Pas d'utilisation par un enfant!
- NL** Geen bediening door kinderen!
- I** Non lasciare utilizzare il tagliacarte a bambini!
- E** No dejar que la utilicen los niños!
- S** Installera maskinen utom räckhåll för barn!
- FIN** Asentakaa laite lasten ulottumattomiin!
- N** Installer maskinen utenfor rekkevidde for barn!
- PL** Dzieciom nie wolno obsługiwać urządzenia!
- RUS** Не допускайте детей к пользованию аппаратом!
- H** Gyerekek a gépet nem kezelhetik
- TR** Makinayı Çocuklar Kullanmamalıdır.
- DK** Må kun betjenes af voksne
- CZ** Stroj nesmí být obsluhován dětmi
- P** As crianças as não devem trabalhar com a máquina!
- GR** ΑΠΑΓΟΡΕΥΕΤΑΙ Η ΧΡΗΣΗ ΑΠΟ ΠΑΙΔΑ.



- D** Nicht in das Schneidwerk greifen!
- GB** Do not reach into the feed-opening of the cutting head!
- F** Ne pas introduire les mains dans le bloc de coupe!
- NL** Blijf buiten het bereik van de invoeropening!
- I** Non toccare il meccanismo di taglio (apertura di alimentazione)!
- E** No Introducir la mano en la abertura de alimentación del cabezal de corte!
- S** Använd inte fingrarna i öppningen till skärverket!
- FIN** Älkää työntäkö sormia teräpakkaan!
- N** Bruk ikke fingrene i åpningen til skjæreverket!
- PL** Nie wkładać rąk pomiędzy głowice tnące!
- RUS** Не допускайте попадания рук в приемное отверстие режущей головки!
- H** Ne nyúljon a vágószerkezetbe!
- TR** Lütfen kesici kafaların çekme sürme ağızlarına dokunmayınız
- DK** Hold fingere væk fra åbningen til skæreværket
- CZ** Nesahejte do vstupní šterbiny a nedotýkejte se rezacího mechanismu!
- P** Não mexer dentro da abertura de alimentação o do cabeça de corte!
- GR** ΜΗΝ ΑΓΓΙΖΕΤΕ ΤΥΟΣ ΚΥΛΙΝΔΡΟΥΣ ΚΟΠΗΣ.

**For NATIONWIDE SERVICE Call 1(800)225-9293**



- D** Vorsicht bei langen Haaren!  
**GB** Long hair can become entangled in cutting head!  
**F** Attention aux cheveux longs!  
**NL** Pas opmet lang haar!  
**I** Capelli lunghi possono entrare nella testa di taglio!  
**E** Tener cuidado con el cabello largo puede enredarse en el cabezal de corte!  
**S** Undvik långt hår i närheten av skärverket!  
**FIN** Varokaa pitkien hiusten joutumista teräpakkaan!  
**N** Vær forsiktig med langt hår i nærheten av skæreverket!  
**PL** Uwaga na długie włosy!  
**RUS** Избегайте попадания длинных волос в механизм аппарата!  
**H** Vigyázzon a hosszú hajra!  
**TR** Uzun saçlara dikkat. Kesici kafalar tarafından içeri çekilebilir.  
**DK** Undgå langt hår i nærheden af skæreværket  
**CZ** Dlouhé vlasy mohou být zachyceny a vtaženy do rezacího mechanismu!  
**P** O cabelo comprido pode ficar preso na cabeça de corte!  
**GR** ΚΡΑΤΕΙΣΤΕ ΜΑΚΡΙΑ ΑΠΟ ΤΗΝ ΕΙΣΟΔΟ ΤΡΦΟΔΟΣΙΑΣ.



- D** Vorsicht bei Krawatten und langen Kleidungsstücken!  
**GB** Take care of ties and other loose pieces of clothing!  
**F** Attention au port de cravats et autres vêtements flottants!  
**NL** Let op met stropdassen en andere losse kledingdelen!  
**I** Attenzione alle cravatte e altre parti sporgenti di stoffa!  
**E** Tener cuidado con las corbatas y todo tipo de prendas sueltas!  
**S** Var aktsam med slipsar och andra lösa delar av klädsen!  
**FIN** Varokaa solmíotanne ja muita pitkiä vaatekappaleitanne!  
**N** Vær forsiktig med slips og løse klesplagg!  
**PL** Uwaga na krawaty i inne luźne części garderoby!  
**RUS** Остерегайтесь попадания галстука и других частей одежды!  
**H** Vigyázzon a nyakkendore és logo ruházatra!  
**TR** Lütfen Gravat ve uzun giysi uzantılarına dikkat ediniz.  
**DK** Undgå løse eller hængene klæder i nærheden af skæreværket  
**CZ** Pozor na kravaty a volné součásti odevu!  
**P** Cuidado com as gravatas ou outro tipo de roupa solta!  
**GR** ΓΡΑΒΑΤΕΣ, ΚΡΕΜΑΣΤΑ ΡΟΥΧΑ ΚΑΙ ΚΟΣΜΗΜΑΤΑ

**For NATIONWIDE SERVICE Call 1(800)225-9293**



- D** Vorsicht bei Schmuck!  
**GB** Be careful of loose jewellery!  
**F** Attention au port de bijoux!  
**NL** Let op met halskettingen en andere juwelen!  
**I** Attenzione ai gioielli!  
**E** Tener cuidado con las joyas!  
**S** Var aktsam med lost hängande smycken!  
**FIN** Varokaa korujen joutumista teräpakkaan!  
**N** Vær forsiktig med løsthengende smykker!  
**PL** Ostrożnie z biżuteria!  
**RUS** Будьте осторожны с длинными свисающими украшениями!  
**H** Vigyázzon az ékszerekkel!  
**TR** Mücevherlerinizin uzun parçalarına dikkat ediniz.  
**DK** Udbgå løse smykker i nærheden af skæreværket  
**CZ** Pozor na volné šperky!  
**P** Cuidado com os colares!  
**GR** ΚΙΝΔΥΝΟΣ ΤΡΑΥΜΑΤΙΣΜΟΥ.

**For NATIONWIDE SERVICE Call 1(800)225-9293**

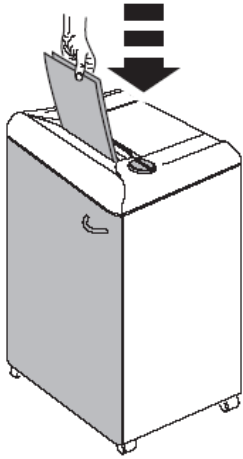

The door must be closed when operating the document shredder!

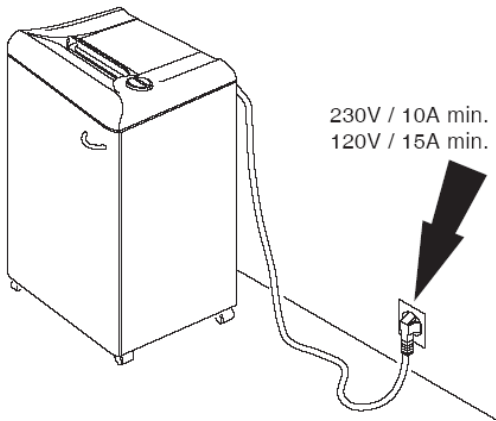

Ensure free access to mains.

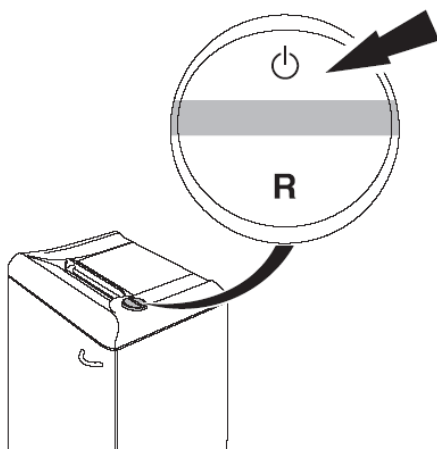

When not in use for a longer period of time switch off.

**For NATIONWIDE SERVICE Call 1(800)225-9293**

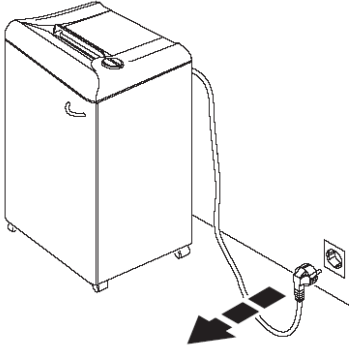

Remove the plug before cleaning the machine.

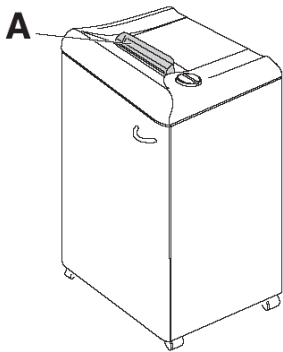

Do not operate the machine without the safety flap.



ON/OFF → Quick stop → Open the door.

**For NATIONWIDE SERVICE Call 1(800)225-9293**

## INSTALLATION

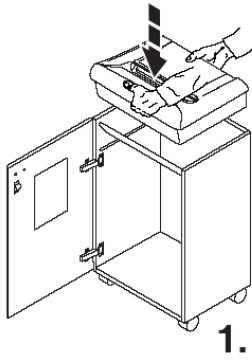

Open the door and put the machine onto the cabinet so that the control panel is facing the door. Beware of fingers.

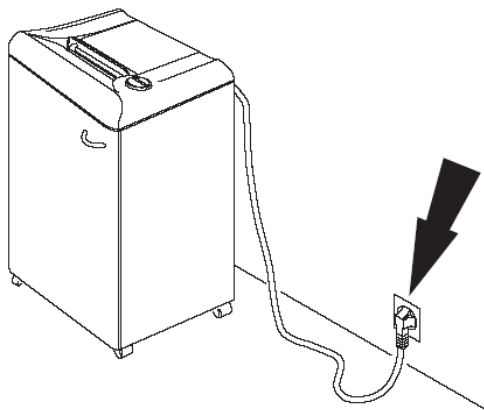
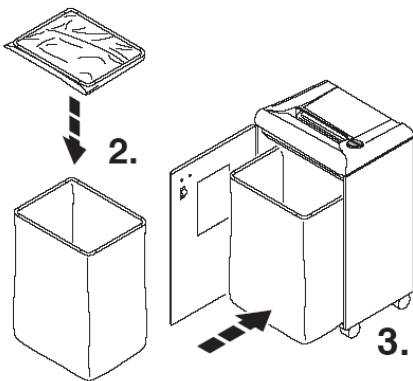

Close the door. Plug into the wall socket.

**For NATIONWIDE SERVICE Call 1(800)225-9293**

## OPERATION

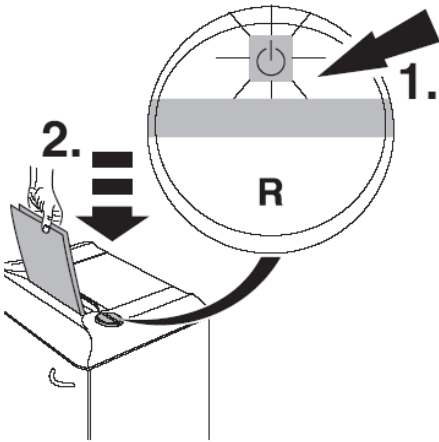

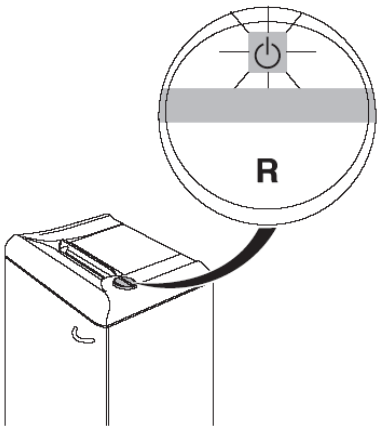

Press the rocker switch  : green light is on, the machine is now ready for operation. Starts automatically when paper is inserted.

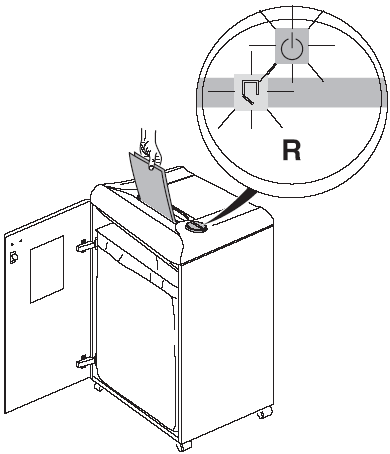

Stops automatically when no further paper is inserted.



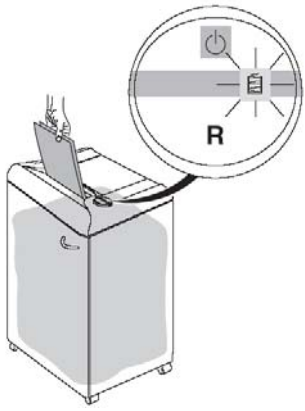

Stops automatically when door is opened symbols  and  flash alternatively.

**For NATIONWIDE SERVICE Call 1(800)225-9293**

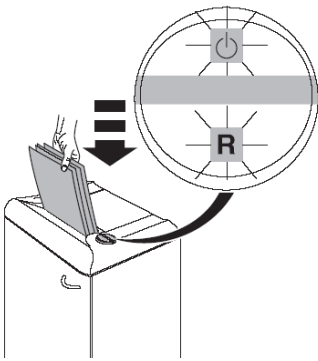

Stops automatically when plastic bag is full. Empty the bag when “bag full” indicator  lights (see page8).



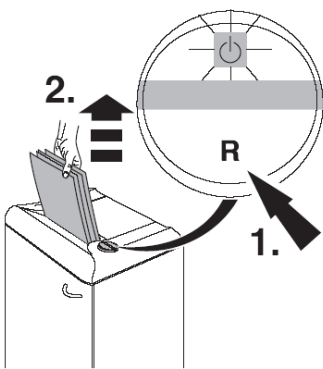

Stops automatically if too much paper is inserted.  
Automatic reverse if paper jams (Symbol “ON/OFF”  flashes).





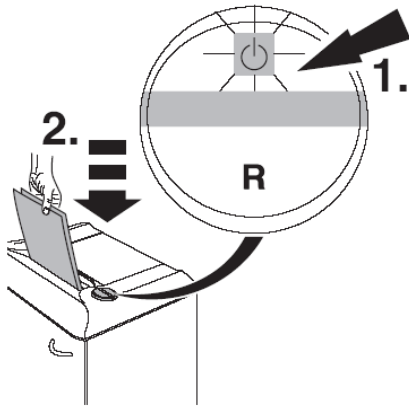

**If required:** Press the rocker switch “R” and remove paper. Machine runs for a short time in reverse, if required repeat several times).

**For NATIONWIDE SERVICE Call 1(800)225-9293**

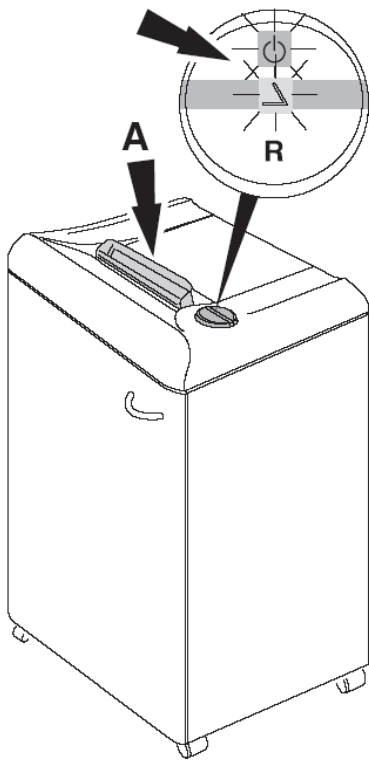

Reset by pressing the rocker switch . Re-feed the paper in smaller quantities.



Automatic stop if safety flap (A) is opened (symbols  and  flash alternatively). Close the safety flap and press the rocker switch , paper is shredded. To remove any paper debris from paper jam the machine runs for a short time reverse with open safety flap. If required press the rocker switch “R” several times.

**For NATIONWIDE SERVICE Call 1(800)225-9293**

## MAINTENANCE

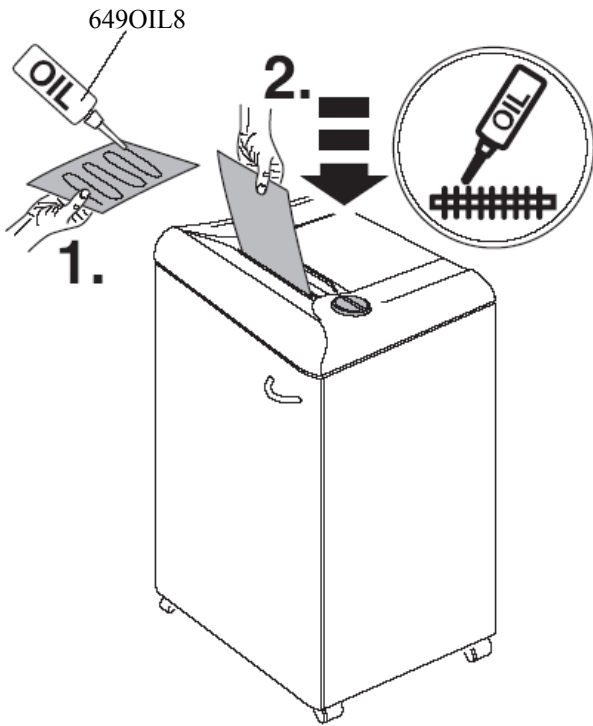

If the sheet capacity reduces or after the bag is emptied we recommend that you oil the shredding mechanism! (see picture).

**For NATIONWIDE SERVICE Call 1(800)225-9293**

# TROUBLESHOOTING

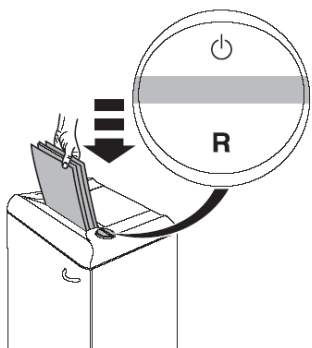

Machine will not start

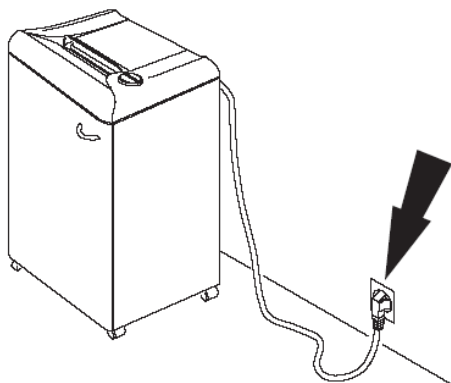

Is the machine plugged in?

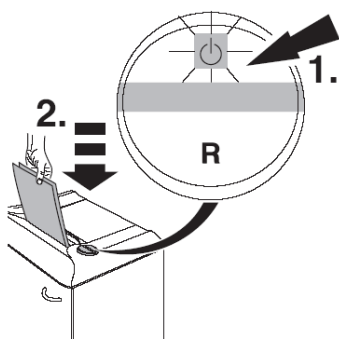

Is the rocker switch  pressed? Is the green light rocker switch is ON (1)? Insert paper (2).

**For NATIONWIDE SERVICE Call 1(800)225-9293**

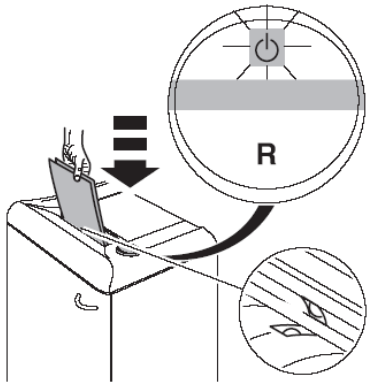

Feed the paper into the center of the feed opening (photo cell).

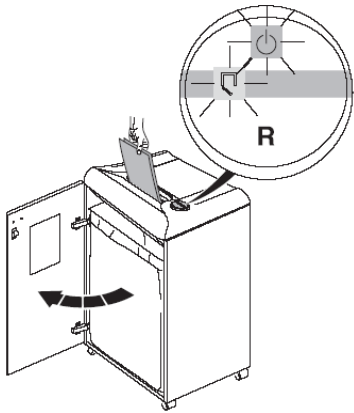

Is the door open?

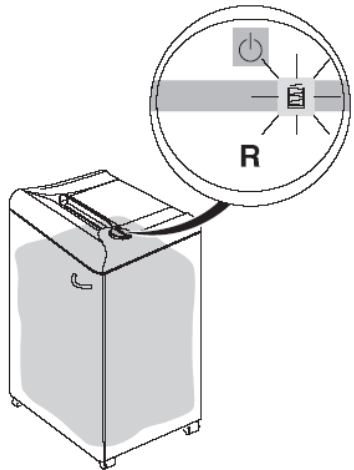

Is plastic bag full?

**For NATIONWIDE SERVICE Call 1(800)225-9293**

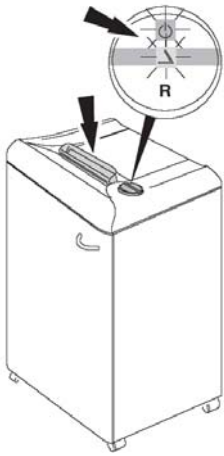

Is the safety flap open?

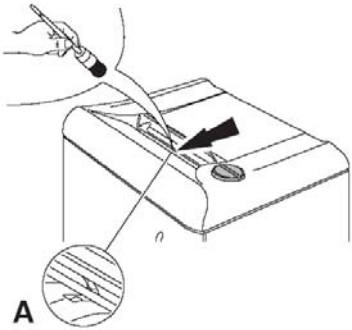

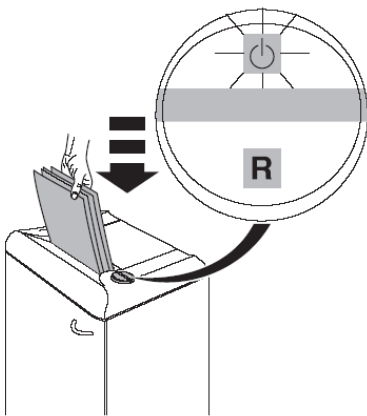

**Machine will not stop:**

Remove plug, clean the photo cell (A) with a small brush.



**Machine Stops:**

Overload protection. Cooling down period approximately 10-15 minutes.

- ⊗ Symbols  and "R" flash alternatively.
- ⊗ Symbol  lights green, machine is ready for operation.

**For NATIONWIDE SERVICE Call 1(800)225-9293**

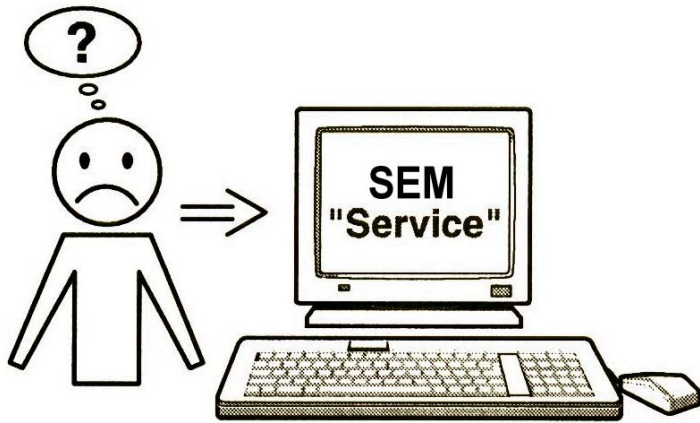

None of the above methods mentioned helped to solve the problem:

Contact Customer Service at:

**Security Engineered Machinery**

**5 Walkup Dr**

**PO Box 1045**

**Westboro, MA 01581**

**Tel: 800/225-9293**

**Tel: 508/366-1488**

**Fax: 508/366-1671**

**Email: [info@semshred.com](mailto:info@semshred.com)**

**For NATIONWIDE SERVICE Call 1(800)225-9293**

## ACCESSORIES



Oil is environmentally friendly.

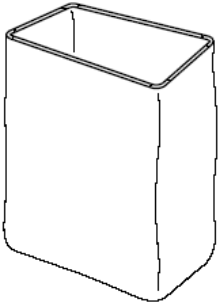

Spare replacement plastic bags.

**For NATIONWIDE SERVICE Call 1(800)225-9293**

## TECHNICAL INFORMATION



Do not shred paper clips

QUALITÄTSMANAGEMENTSYSTEM



DQS-zertifiziert nach  
DIN EN ISO 9001 : 2000  
Reg.-Nr. 1489 QM

The machine is approved by independent Safety laboratories and is in compliance with the EC-regulations 98/37/EG, 2006/95/EG and 2004/108/EG.



### **Sound level information:**

The sound level at the work place is less than the than the ISO 7779 standard's maximum permissible level of <70db (A).



The exact technical specifications can be found on the technical specifications stickers on the machine.



Subject to alterations with out notice.

### EC-declaration of conformity

Herewith we declare that the Model 1324S and 1324P complies with the following provisions applying to it 98/37/EG; 2006/95/EG; 2004/108/EG.

Applied harmonized standards in particular EN 60950-1; EN 55014-1; EN 55014-2; EN 61000-3-2; EN 61000-3-3; EN ISO 12100-1; EN ISO 12100-2; EN 294; ISO 7779.

**For NATIONWIDE SERVICE Call 1(800)225-9293**



# Security Engineered Machinery Co., Inc. Product Information



## Paper Shredders, Disintegrators/Industrial Shredders

Contract Number: GS-02F-0111P  
 Contract Period: October 1, 2006 to September 30, 2011  
 C3615 Shredders  
 C3615 Accessories/Attachments for Shredders and Disintegrators  
 C3615 Spare Parts for Shredders and Disintegrators  
 C3615 Disintegrators  
 C3615 Remanufactured Disintegrators



## Information Technology

Contract Number: GS-35F-0297J  
 Contract Period: March 17, 1999 to May 15, 2009  
 132-8 Purchase of Equipment, FSC Class 7010, (IT)  
 132-12 Maintenance, Repair Service/Spare Parts, FPDS Code J070



## Recycling Collection Containers Specialty Waste Receptacle All types of Destruction Services

Open Market

Consult Factory

For detailed product information including all application and specifications, contact our Customer Service Department at 1-800-225-9293 or visit us on line at [www.semshred.com](http://www.semshred.com) for commercial customers and [www.fedshred.com](http://www.fedshred.com) for government customer.

# Mod. 1324 CROSS / CUT 0,8x5mm CCC A

01.11.2006

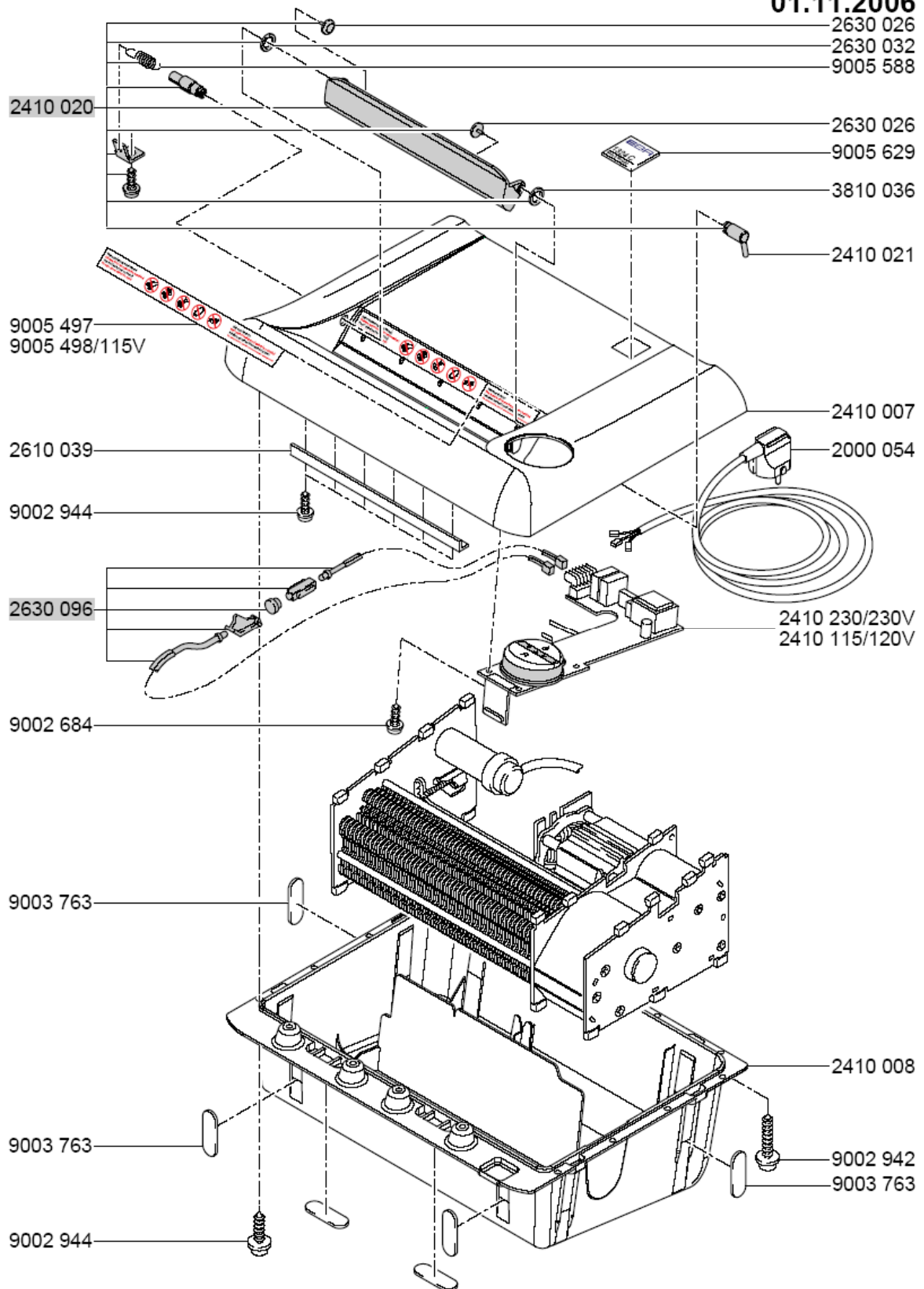

# Mod. 1324 CROSS / CUT CCC A

0,8x5mm  
01.11.2006

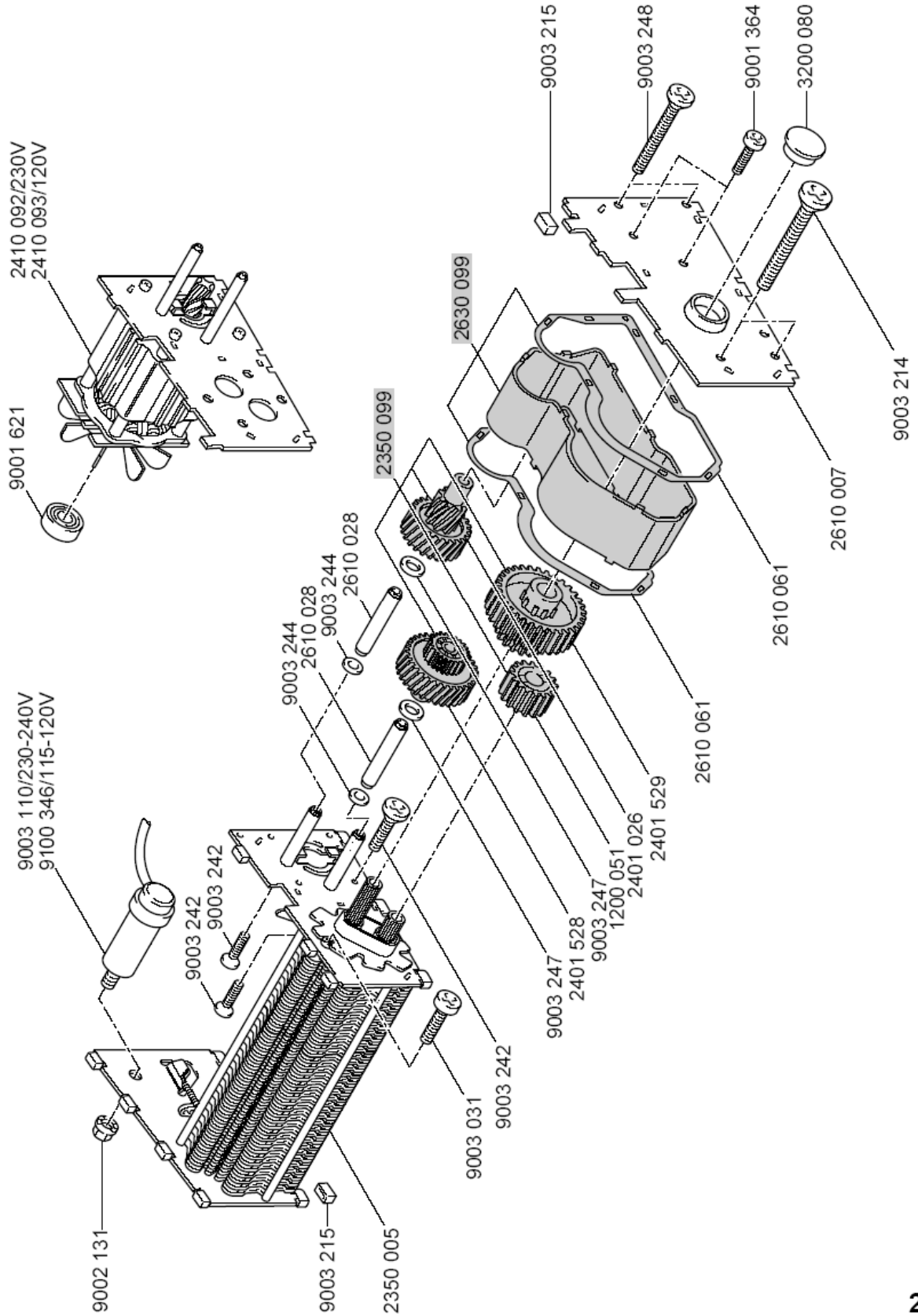

CROSS / CUT 0,8x5mm  
**Mod.1324 CCC A**  
01.11.2006

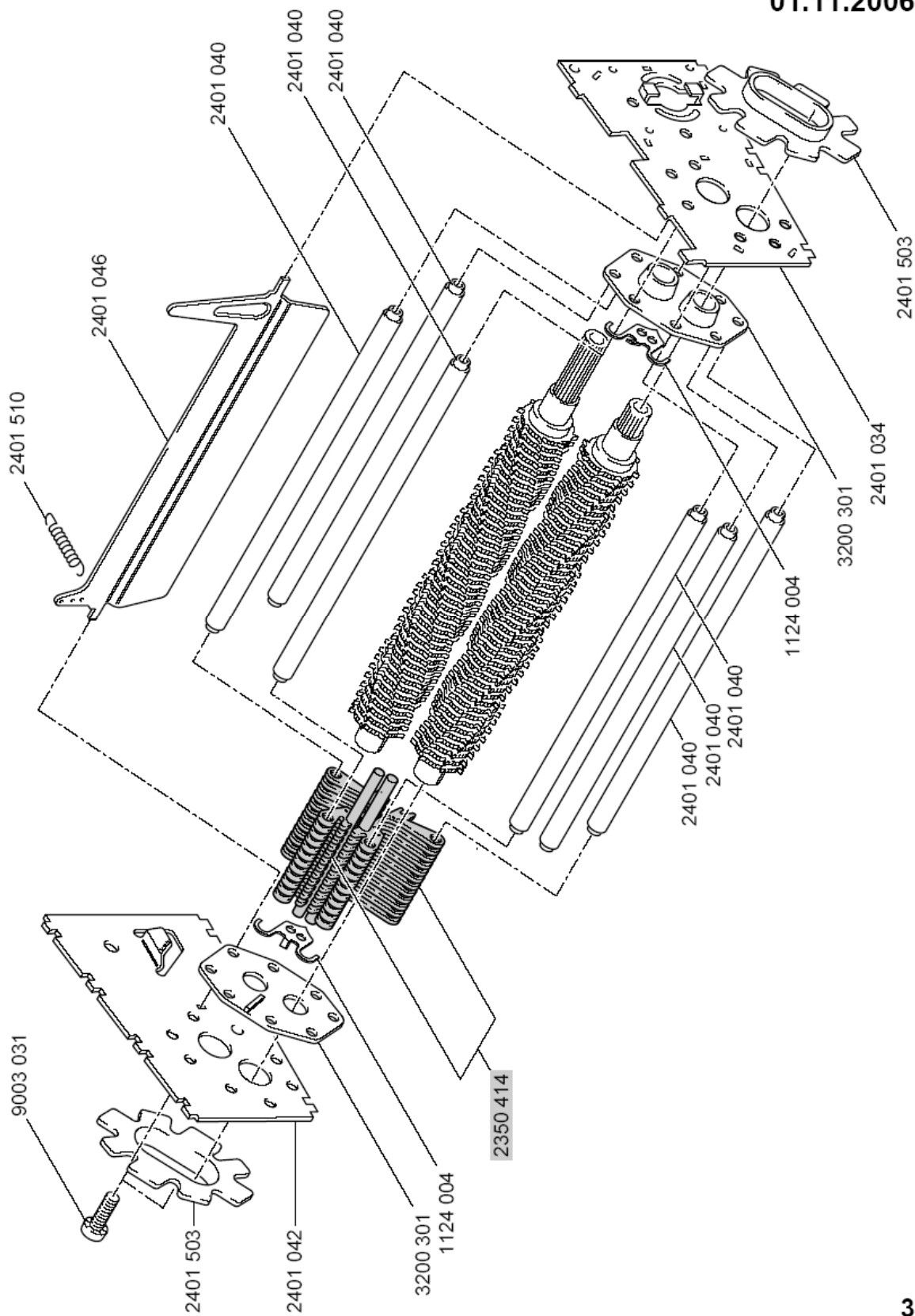

# Mod. 1324 **CROSS / CUT** **CCC A**

0,8x5mm

01.11.2006

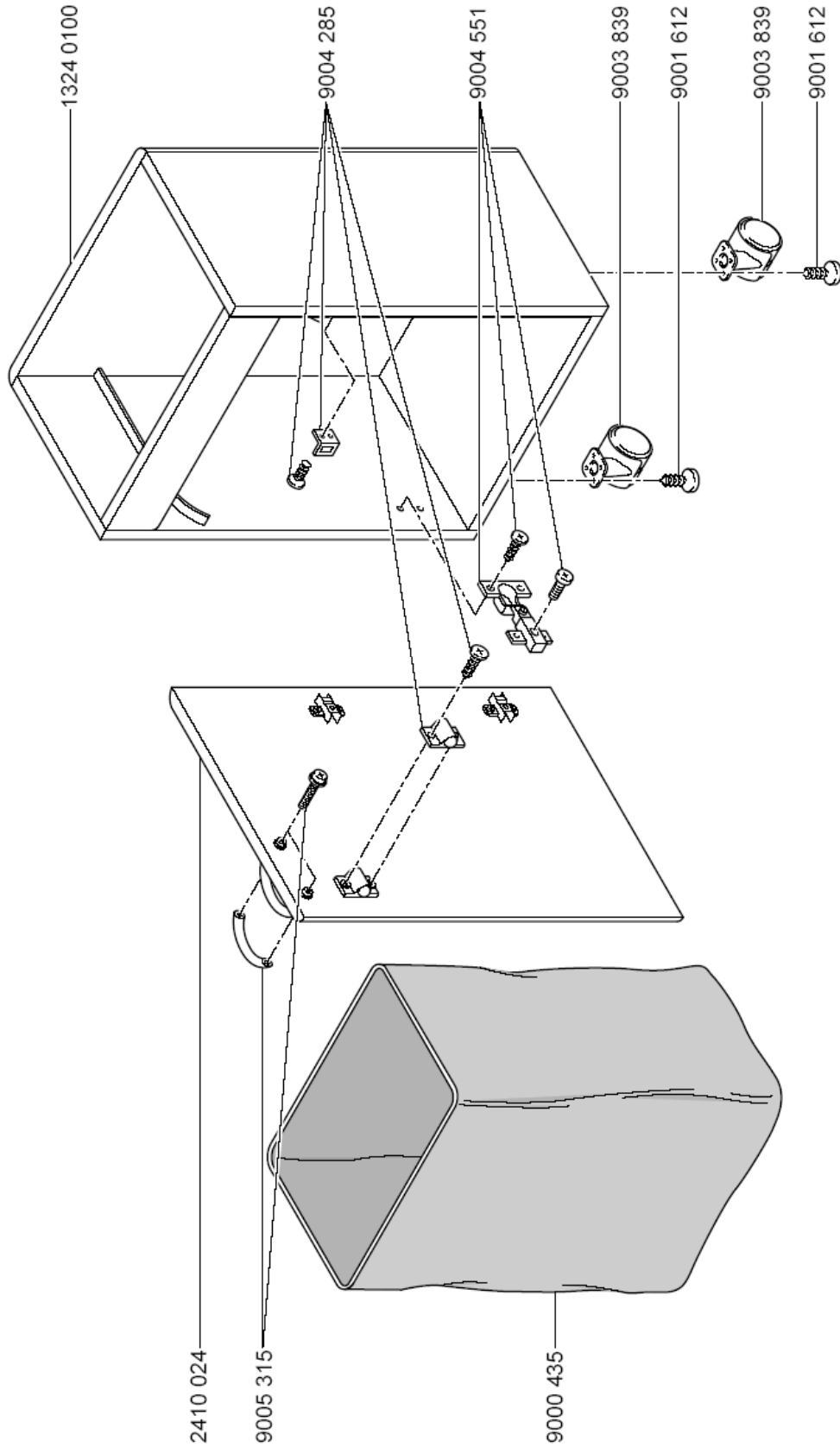

# Mod.1324 **CROSS / CUT** CCC A 0,8x5mm

01.11.2006

Anschlußplan 1324 CCC A  
 Diagramme de branchement 1324 CCC A  
 Connecting diagram 1324 CCC A

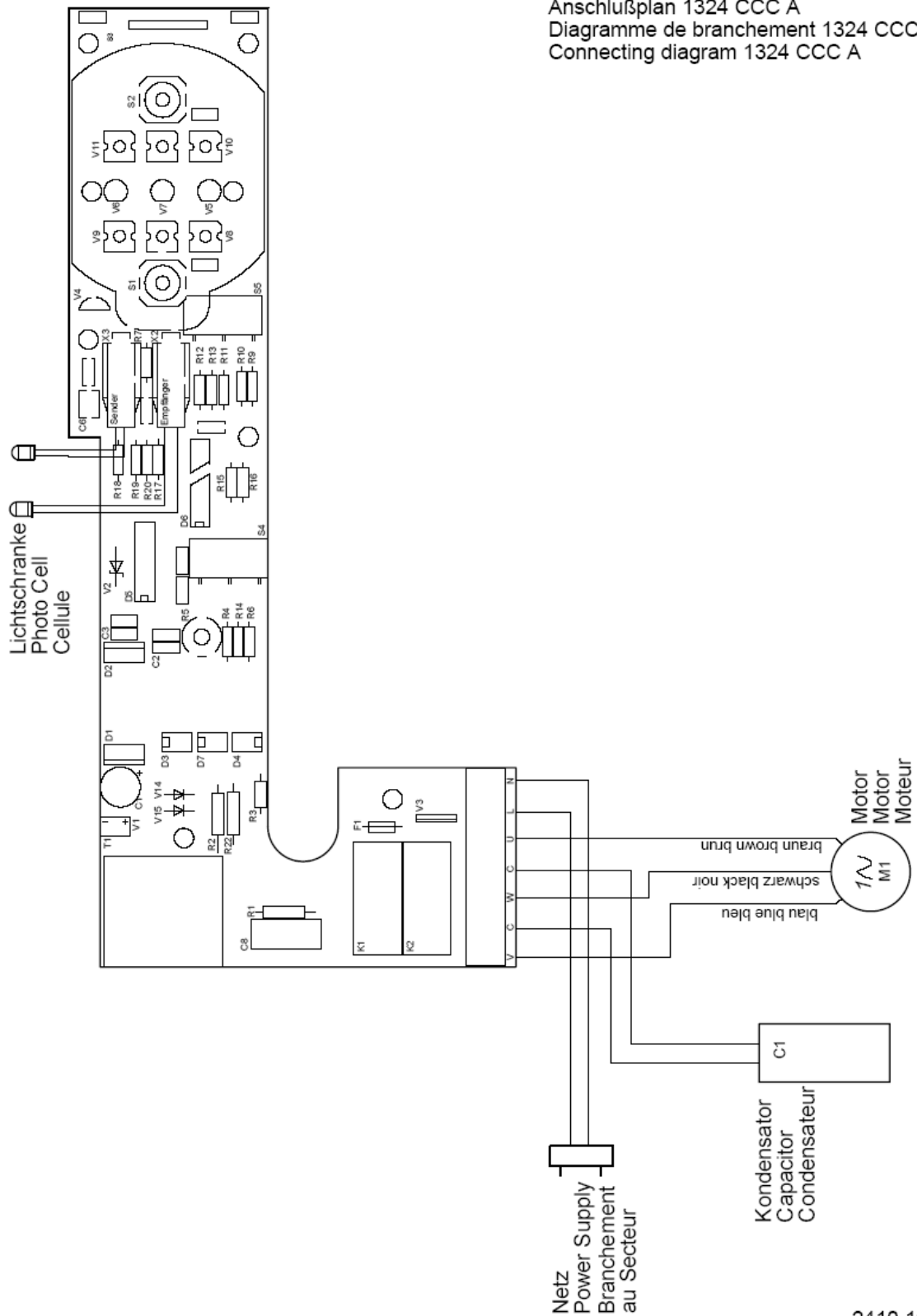

# Mod. 1324 CCC A

CROSS / CUT 0,8x5mm  
01.11.2006

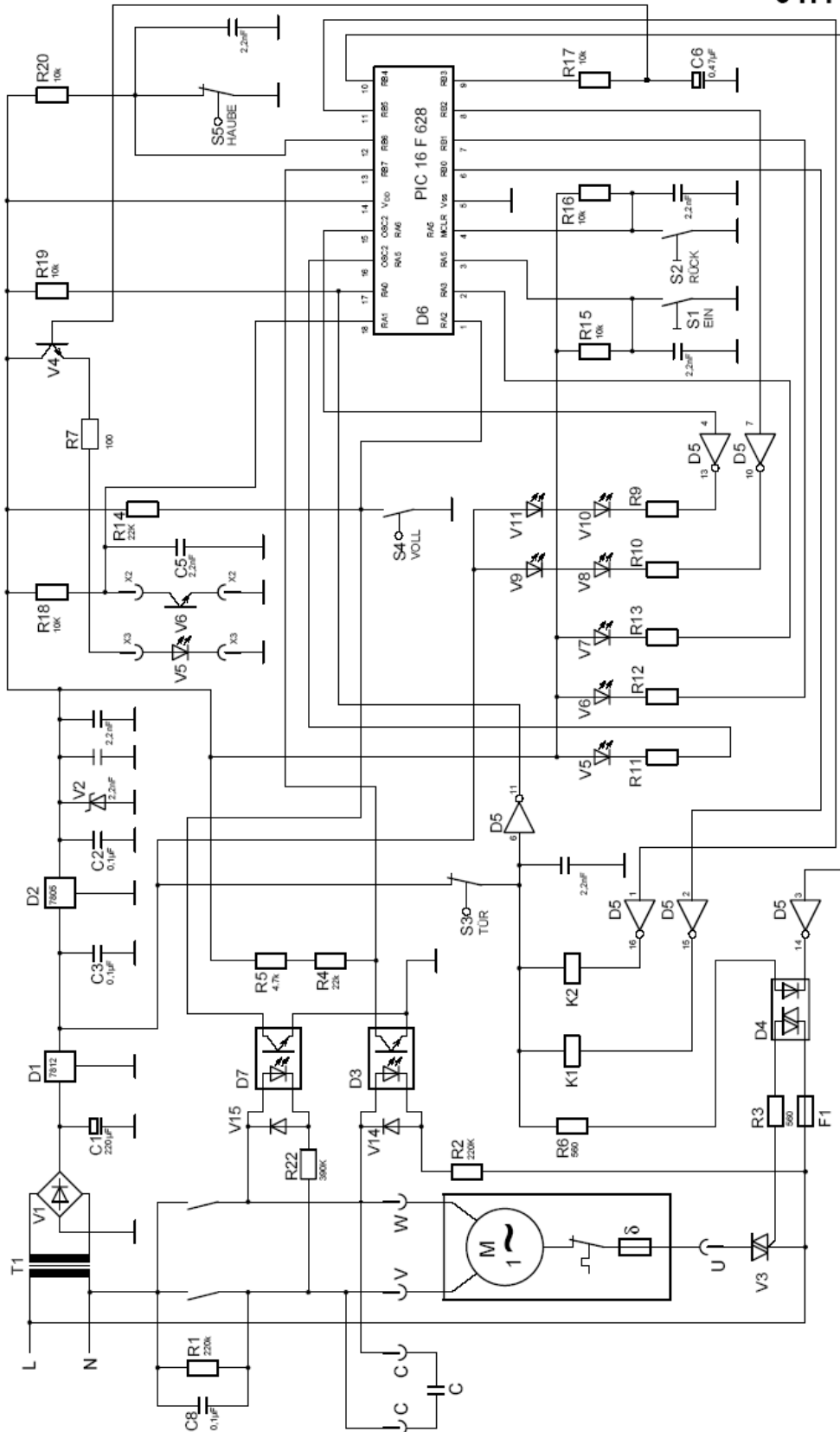

Stromlaufplan 1324 CCC A  
 schema de circuit électrique 1324 CCC A  
 wiring diagram 1324 CCC A