



Security Engineered Machinery Co., Inc

OPERATIONAL & MAINTENANCE MANUAL
For
SEM Model 0101 HD Crusher



Security Engineered Machinery Co., Inc.

NATIONWIDE SERVICE

Phone Toll Free: 1(800)225-9293

Email: Service@SEMSHRED.com

Fax: (508)366-6814

Website: WWW.SEMSHRED.COM

Rev. 0
Created: 04/08/08

IMPORTANT SAFETY PROCEDURES

Your new SEM Hard Drive Crusher incorporates powerful, heavy duty pressing mechanisms, **serious and permanent injury may result** if proper precautions are not followed.



1. This equipment should never be operated by children or individuals that are untrained or incapable of understanding these safety precautions!



2. Do not reach into the feed opening for any reason! Never insert fingers, hands, other extremities, or objects not meant to be crushed into the feed opening!



3. Do not operate or come into close proximity to this equipment wearing loose clothing, neckties, dangling jewelry, or long hair which may become entangled in the crushing chamber.



4. Maintenance or repair of this equipment should be performed only by trained, authorized service personnel.

5. Always disconnect electric power (unplug) before removing or opening any cover or other panels providing access to the internal mechanisms.

For NATIONWIDE SERVICE call 1(800)225-9293

Table of Contents

READ CAREFULLY BEFORE USING

Proper care of your new Hard Drive Crusher will ensure many years of trouble free operation, with a minimum of maintenance or repair.

CAUTION: Before operating the Hard Drive Crusher, the reservoir plug needs to be removed and replaced with the breather vent supplied with the Crusher unit. This plug should also be retained in the event that the crusher unit should need to be re-shipped in order to avoid spillage of hydraulic fluid. See the installation instructions for further detailed information.

<u>Contents</u>	<u>Page No.</u>
Safety Procedures.....	2
Table of Contents.....	3
Installation and Setup.....	4
Operation and Overloading.....	5
Troubleshooting.....	6
Preventative Maintenance Options Available.....	6
Specifications and Service Instructions.....	6
Using and Ordering Spare Parts.....	7
Diagrams and Part Numbers.....	8
SEM Products.....	11

Customer Service

Security Engineered Machinery, Co. Inc.

PO Box 1045

Westboro, MA 01581

Tel: 800-225-9293

Fax: 508-366-1671

Website: www.semshred.com

E-mail: info@semshred.com

Order On-line:

GSA Customers: www.fedshred.com

Commercial Customers: www.semshred.com

For NATIONWIDE SERVICE call 1(800)225-9293

INSTALLATION AND SET-UP

The SEM Model 0101 HD Crusher must be installed on a 120V/1/60Hz, grounded electrical line service. The crusher is equipped with a 15 Amp, (3) three prong plug on the power cord.

After removing the HD Crusher from its packaging, be sure that all paperwork and any loose items that may have been shipped with the Crusher have been removed from the packaging as well. ***Please note that all packaging should be retained by the customer for (30) days from the time of receipt. In the event that this unit needs to be sent back for replacement or repair this packaging will be required to do so. Should the packaging have been discarded before the (30) day requested period, packaging costs will be incurred by the customer.*** Be sure to place the HD Crusher unit on a strong and sturdy surface.

It is very important to replace the reservoir plug with the supplied breather vent prior to using this unit. **DO NOT OPERATE THE CRUSHER WITH THE SHIPPING PLUG IN THE RESERVOIR!**

The reservoir plug is located inside of the HD Crusher cabinet. With the crusher still unplugged and facing the unit from the front, locate the small access door on the right hand side of the crusher. This access door is secured by (2) hex head cap screws. Remove both of these screws and open the door.



Inside you will find the reservoir plug, unscrew the plug and replace it with the breather vent by screwing it back into place, remember to retain the reservoir plug to be used when shipping or moving this unit.



For NATIONWIDE SERVICE call 1(800)225-9293



Close the access door and replace the (2) screws. You can now plug the unit into a power receptacle; you are now ready to use your Model 0101 HD Crusher.

OPERATION

The SEM Model 0101 HD Crusher features an automatic on/off toggle switch for simple and convenient operation.

1. To turn the HD Crusher on, flip the motor starting toggle switch to the “on” position. The electric motor-hydraulic pump unit will activate and run as long as the toggle switch is in the “on” position.
2. In order to stop movement of the HD Crusher at any time, push the “Emergency Stop” button.
3. To begin crushing, open the front access door and place the hard drive into the crushing chamber, then close the access door. Please note that the HD Crusher will not function if the access door is left open. With the access door closed press the button marked “down”, the Crusher Spear will begin to descend and pierce the hard drive in the Crusher Chamber, when it has reached the end of its cycle it will ascend upward. You can now remove the hard drive from the chamber once the Crusher Spear has ascended completely upward.
4. Once you have completed crushing your hard drives, simply turn the HD Crusher off by flipping the motor starting toggle switch to the “off” position.

OVERLOADING

Should too much material be fed into the crusher, it will switch off automatically. Please allow the system to cool down, ensuring the crushing piston is in its stand-by position and run without any drives for (2) cycles.

For NATIONWIDE SERVICE call 1(800)225-9293

TROUBLESHOOTING

Issue: Crusher Spear will not move down when pushing the down button.

Answer: Be sure that the front access door is closed, check to make sure that the emergency stop button is not pushed in, if it is pull the emergency stop button back out, also check to make sure that the power is on, if not flip the motor starting switch to the “on” position.

Issue: Crushing capacity has dropped or the machine jams easily.

Answer: Clean and lubricate the crushing ram, also ensure that there is an adequate supply of hydraulic fluid. *Follow the service instructions for safety and removing the outer cover of the HD Crusher.*

PREVENTATIVE MAINTENANCE OPTIONS AVAILABLE

Two to three preventative maintenance calls per year are recommended. Only authorized service personnel should be allowed to service the crusher.

SEM provides Preventative Maintenance Contracts for many of its products. Contact SEM for a Preventative Maintenance Contract that would fit your needs at 1-800-225-9293.

SPECIFICATIONS

Media Destroyed: All Standard (.65 inch to 1.65 inch) Computer Hard Drives and Laptop Hard Drives.
Power Supply: 120V/1/60 Hz
Destruction Time: 15 second cycle time for all drive types.
Weight: 142 lbs.
Dimensions: 24” high x 10” wide x 24” deep.

SERVICE INSTRUCTIONS

Yearly Instructions:

1. Important: Always unplug the HD Crusher before performing any maintenance.
2. Loosen the electrical cord grommet screws located on the rear panel.
3. Remove the top cover by removing the screws on both sides of the cover. Be careful when lifting the cover to ensure that damage is not done to the electrical cords or electrical control equipment during lifting.
4. Drain the hydraulic fluid from the reservoir, clean out any debris or foreign material from the reservoir and replace with SAE 20 Universal Automatic Transmission Fluid. Fill the reservoir to the level indicated on the reservoir.

For NATIONWIDE SERVICE call 1(800)225-9293

5. Carefully replace the cover back onto the HD Crusher by first sliding the electrical cord through the rear grommet and sliding the cover back over the HD Crusher again being sure not to damage any of the cords or electrical components. Re-install and tighten all screws on the side of the cover as well as the grommet screws in the rear panel.

USING AND ORDERING SPARE PARTS

- Only use original SEM spare part replacements.
- We guarantee their quality and functional reliability.
- Warranty claims on parts and/or service must be approved by SEM's Customer Service Manager.

HINTS FOR ORDERING SPARE PARTS

The spare parts shown on the following pages have part numbers associated with this product. This spare parts list shows the following information with respect to the spare parts to be ordered.

- Part number
- Dimensions
- Quantity
- Designation
- Item Number

In order to avoid errors and the delivery of wrong parts, each parts order should contain the following information:

- Model Number (See nameplate)
- Part Number and designation of desired spare parts
- Desired mode of shipment (e.g. post, freight)
- Machine Type
- Quantity of desired spare parts
- Full address of purchaser

For NATIONWIDE SERVICE call 1(800)225-9293

PARTS DIAGRAM

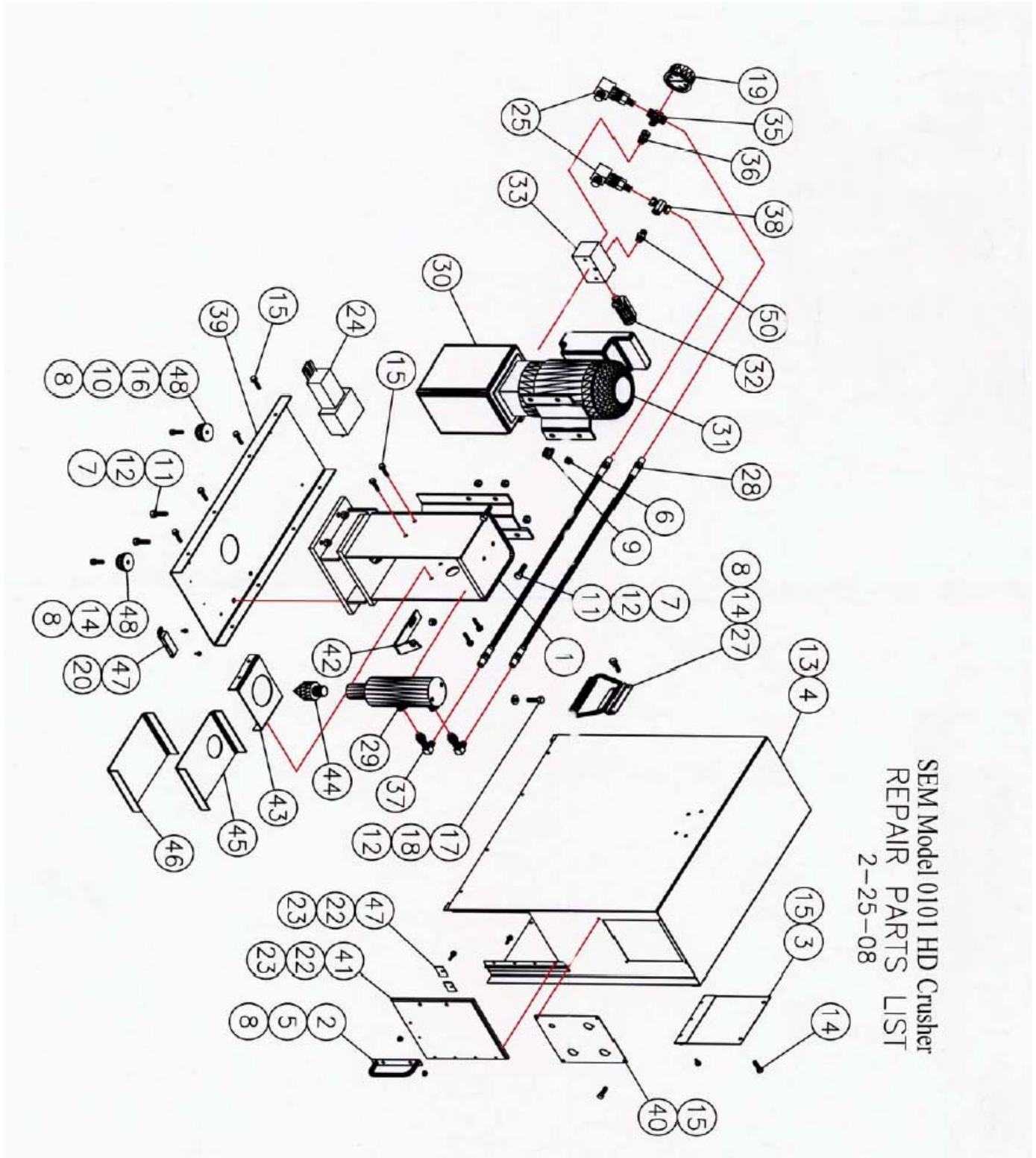

For NATIONWIDE SERVICE call 1(800)225-9293

PARTS LIST

Item	Part No	Description	Qty
1	6183	FRAME WELD	1
2	6184	DOOR HANDLE WELD	1
3	6186	ACCESS DOOR WELD	1
4	6188	COVER PANEL WELD	1
5	13.028	FHCS ¼-20 X ½	2
6	128	PIPE PLUG ¼ NPT SQ HD	1
7	212-N	NUT 3/8-16 NYLOK	8
8	226	¼-20 NYLOK	6
9	350	REDUCER BUSHING ¾ NPT X ¼ NPT	1
10	445	WASH ¼ FLAT WROUGHT	2
11	447	SHCS 3/8-16 X 1-1/4	8
12	700	WAS 3/8 FLAT WROUGHT	18
13	705	ELEC FLEX CONNECT	1
14	903	SHCS ¼-20 X ¾	4
15	979	¼-20 X 1 HEX HD THREAD CUTTING	19
16	1271	SHCS ¼-20 X 1-1/4	2
17	1306	SHCS 3/8-16 X 1 GR5	2
18	1354	WASH 3/8 SPLIT LOCK	2
19	3019	PRESSURE GAUGE	1
20	4239	SELF TAP SLOT PAN HD 8-32 X ½	2
21	4243	CORD, ELEC, W/MOLDED PLUG	1
22	4569	SELF TAP 10-24 X ¾ HEX SLOT WAS HD	6
23	4570	NUT 10-24 NYLOK	6
24	11812	ELECTRONIC CONTROLS PACKAGE	1
25	11812-1	ELECTRONIC CONTROLS	REF
26	11813	DECAL, DISK DESTROYER	1
27	11817	HANDLE, GRAB W/BACKET & PIVOT	1
28	11837	HOSE, HYD ¼ ID SAE 100R2 ¼ NPT X 18	2
29	11842	CYL, 2-1/2 DIA BORE X 2-1/2 STROKE	1
30	11843	POWER UNIT, ELEC, HYD, 1 GAL RES	1

Item	Part No	Description	Qty
26	11813	DECAL, DISK DESTROYER	1
27	11817	HANDLE, GRAB W/BACKET & PIVOT	1
28	11817	HOSE, HYD ¼ ID SAE100R2 ¼ NPT X 18	2
29	11842	CYL, HYD 2-1/2 DIA BORE X 2-1/2 STROKE	1
30	11843	POWER UNIT, ELEC HYD, 1 GAL RES	1
31	11843-1	ELECTRIC MOTOR	REF
32	11843-2	COILS	REF
33	11843-3	VALVE BODY	REF
34	11902	DECAL, MADEL NAME, THE GUARDIAN	2
35	11906	TEE ¼-18(M)NPT X ¼-18(2XF)NPT	1
36	11907	SWIVEL 9/16-18(M) ORING X ¼-18(F)NPT	1
37	11908	ELBOW 9/16-18(M) ORING X 90 JIC 37 DEG	2
38	11909	TEE ¼-18(3XF)NPT 2X SWIVEL	1
39	12131	PANEL, BASE	1
40	12132	PANEL, INSTRUMENT	1
41	12133	PANEL, DOOR	1
42	12139	BRACKET, DOOR SWITCH	1
43	12142	PLATE, GUIDE	1
44	12146	SPEAR	1
45	12149	TRAY, DEBRIS TOP	1
46	12150	TRAY, DEBRIS BOTTOM	1
47	12151	MAGNETIC CATCH-DOUBLE	1
48	12152	FOOT, RUBBER	4
49	12153	SCHEMATIC,ELEC	REF
50	12154	FITTING, RIGID 9/16-18(m)ORINGX ¼-18 NPT	1
51	12155	DECAL, DD601 OP INSTRUCTIONS	1
52	12156	DECAL, DD601 SERVICE INSRTUCTIONS	1

For NATIONWIDE SERVICE call 1(800)225-9293



Security Engineered Machinery Co., Inc. Product Information



Paper Shredders, Disintegrators/Industrial Shredders

Contract Number: GS-02F-0111P
 Contract Period: October 1, 2006 to September 30, 2011
 C3615 Shredders
 C3615 Accessories/Attachments for Shredders and Disintegrators
 C3615 Spare Parts for Shredders and Disintegrators
 C3615 Disintegrators
 C3615 Remanufactured Disintegrators



Information Technology

Contract Number: GS-35F-0297J
 Contract Period: March 17, 1999 to March 15, 2009
 132-8 Purchase of Equipment, FSC Class 7010, (IT)
 132-12 Maintenance, Repair Service/Spare Parts, FPDS Code J070



Recycling Collection Containers Specialty Waste Receptacle
All types of Destruction Services
 Open Market Consult Factory

For detailed product information including all application and specifications, contact our Customer Service Department at 1-800-225-9293 or visit us on line at www.semshred.com for commercial customers and www.fedshred.com for government customer.