



Security Engineered Machinery Co., Inc

OPERATIONAL & MAINTENANCE MANUAL

SEM Model 3130P

REV: 0



As of January 27, 2010

Security Engineered Machinery Co., Inc

NATIONWIDE SERVICE

Phone Toll Free 1(800)225-9293

Email: [**Service@SEMSHRED.COM**](mailto:Service@SEMSHRED.COM)

Fax: (508)366-6814

Website: [**WWW.SEMSHRED.com**](http://WWW.SEMSHRED.com)

Table of Contents

READ CAREFULLY BEFORE USING

Proper care of your new paper shredder will ensure many years of trouble free operation, with minimum of maintenance or repair.

IMPORTANT: *Please note that all packaging should be retained by the customer for (30) days from the time of receipt. In the event that this unit needs to be sent back for replacement or repair this packaging will be required to do so. Should the packaging have been discarded before the (30) day requested period, packaging costs will be incurred by the customer.*

Contents	Page No.
Safety Procedures.....	2-4
Installation and Set-up.....	5
Operation and Feeding	6-8
Troubleshooting.....	9-12
Accessories.....	13
Technical Information.....	14
Parts List	15-20
Additional SEM Products.....	21

Customer Service

Security Engineered Machinery Co., Inc.

PO Box 1045

5 Walkup Drive

Westboro, MA 01581

Tel: 800-225-9293

Fax: 508-366-6814

Website: www.semshred.com

E-mail: info@semshred.com

Order On-line:

GSA Customers: www.fedshred.com

Commercial Customers: www.semshred.com

IMPORTANT

Two to three preventive maintenance calls per year are recommended

Only authorized SEM service personnel should be allowed to service the shredder.

For NATIONWIDE SERVICE Call 1 (800) 225-9293

IMPORTANT SAFETY PROCEDURES

Your new paper shredder incorporates powerful, heavy duty cutting mechanisms, **serious and permanent injury may result** if proper precautions are not followed.



1. This equipment should never be operated by children or individuals that are untrained or incapable of understanding these safety precautions!



2. Do not reach into the feed opening for any reason! Never insert fingers, hands, other extremities, or objects not meant to be shredded into the feed opening!



3. Do not operate or come in close proximity to this equipment wearing long hair, necktie, loose clothing, or jewelry which may activate a photoelectric on/off switch and/or be pulled into the shredder.



4. Maintenance or repair of this equipment should be performed only by trained, authorized service personnel.

5. Always disconnect electrical power (unplug) before removing or opening the cover or other panels providing access to internal mechanisms.

SPECIFICATIONS

Shred Size	5/32" x 1-5/32"
Sheet Capacity *	Up to 22 Sheets
Feed Opening	16"
Bin Capacity	42 Gallon
Dimensions	38.5"H x 25"W x 23"D
Weight	180 lbs.

*Results may vary depending on power source, operator/proper maintenance and paper type.

For NATIONWIDE SERVICE Call 1 (800) 225-9293

IMPORTANT SAFETY PROCEDURES

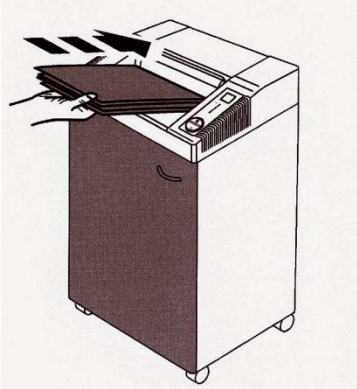

The door must be closed when operating the document shredder.

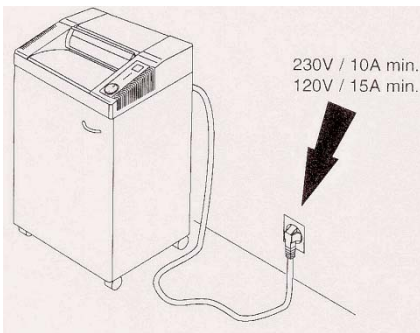

Ensure free access to mains.

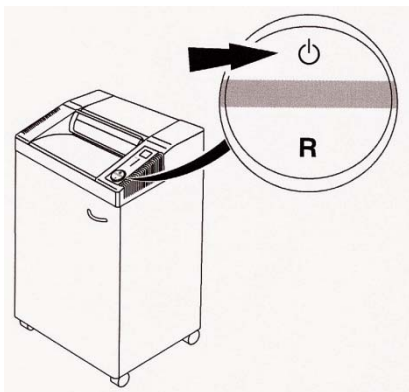

Automatic standby that switches off after 1 hour.
Green LED  control light is off.

For NATIONWIDE SERVICE Call 1(800) 225-9293

IMPORTANT SAFETY PROCEDURES

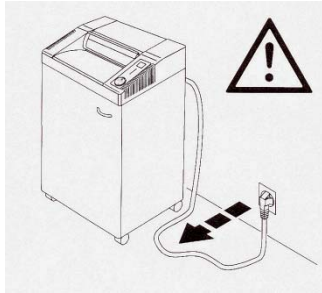

Unplug from the main before cleaning the machine!



Do not operate the machine without the safety flap (A).

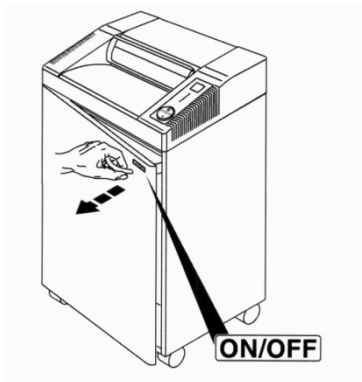

ON/OFF→Quick Stop→Open the door!

For NATIONWIDE SERVICE Call 1(800)225-9293

INSTALLATION

EDA 2020-2, EDA 2020, EDA 2021
EDA 2030, EDA 2140

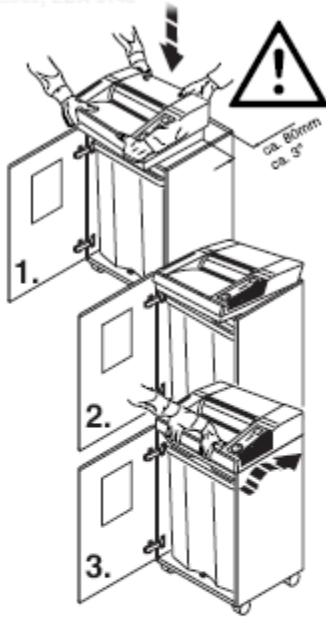

Open the door; place the machine into the top of the cabinet. We recommend that two people set up this unit! Beware of fingers! Risk of injury! All machines have a container with plastic bag.

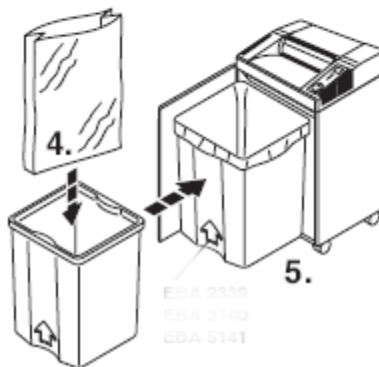

Close the door; Plug into wall socket.

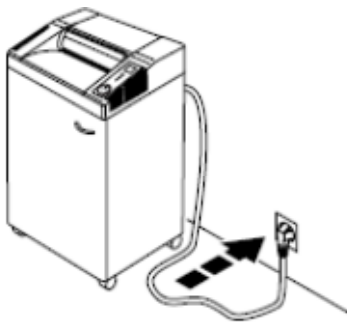

For NATIONWIDE SERVICE Call 1(800)225-9293

OPERATION

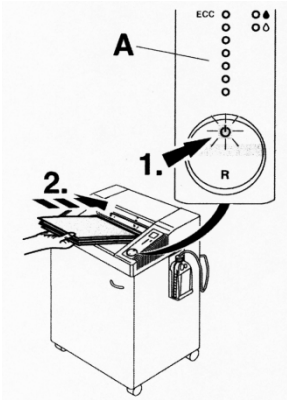

Press the rocker switch ① (1): green light is on, the machine is now ready for operation. Starts automatically when paper is inserted. Automatic standby that switches off after (1) one hour Green LED ① control light is off. Model 2226CC/3 has an ECC – display (electronic capacity control) which indicates the used sheet capacity during Shredding process (A).

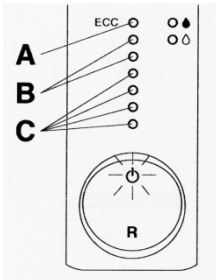

LED shows red (A).

Stops automatically if too much paper is inserted.
Automatic reverse if too much paper is inserted.

LED shows yellow (B).

Maximum sheet capacity during shredding process.

LED Shows green (C).

Normal sheet capacity during shredding process.

Important: Between paper insertion allow the machine to return to the LED green light. (C) If you insert paper while the LED yellow light (B) is lit you may cause a paper jam, (See page 9 for paper jams).





Stops automatically when no further paper is inserted.

For NATIONWIDE SERVICE Call 1(800)225-9293

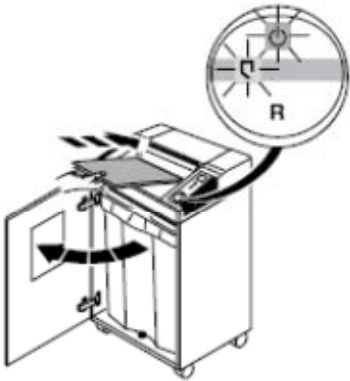
OPERATION Cont....



Stops automatically when door is opened symbols  and  flash alternatively.

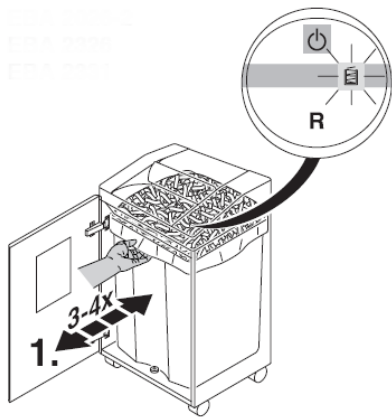

Stops automatically when plastic bag is full. Empty the bag when “bag full” indicator  lights. (see page 5 fig. 4)

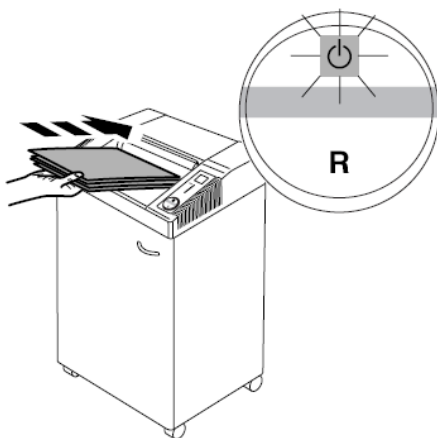

Stops automatically if too much paper is inserted. Automatic reverse if paper jams (Symbol “ON/OFF”  flashes).

OPERATION Cont....

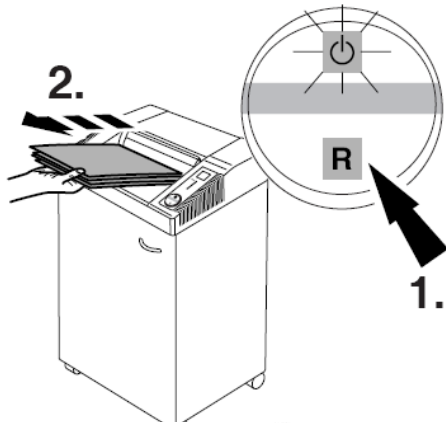

If required: (Paper Jam)

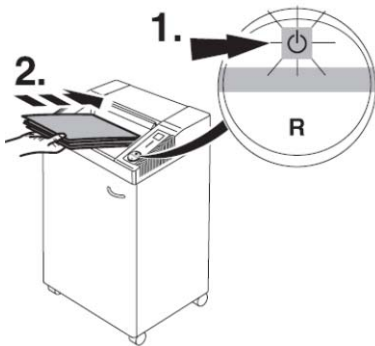

Press the rocker switch “R” and remove paper. (Machine runs for a short time in reverse, if required repeat several times).

Reset by pressing the rocker switch . Re-feed the paper in smaller quantities.

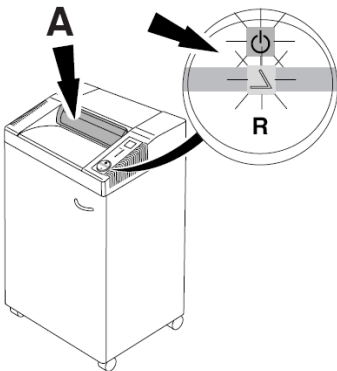

Reset by pressing the rocker switch .
Re-feed the paper in, smaller quantities



Automatically stops if safety flap (A) is opened (symbols  and  flash alternatively). Close the safety flap and press the rocker switch  paper is shredded. To remove any paper debris from a paper jam the machine runs for a short time reverse with open safety flap. If required press the rocker switch “R” several times.

For NATIONWIDE SERVICE Call 1(800)225-9293

TROUBLESHOOTING

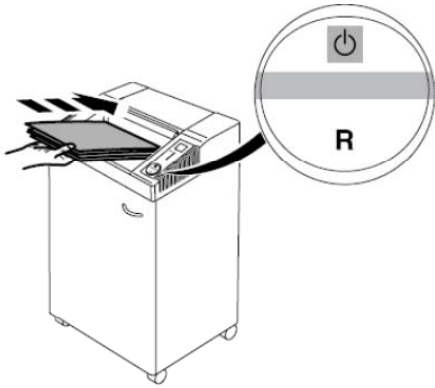

Machine will not start.

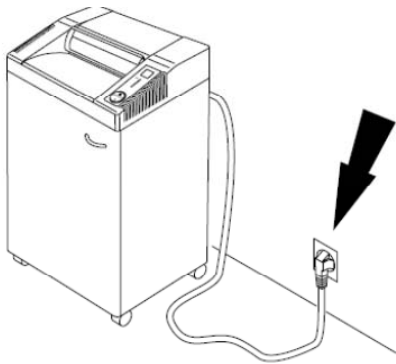

Is the machine plugged in?

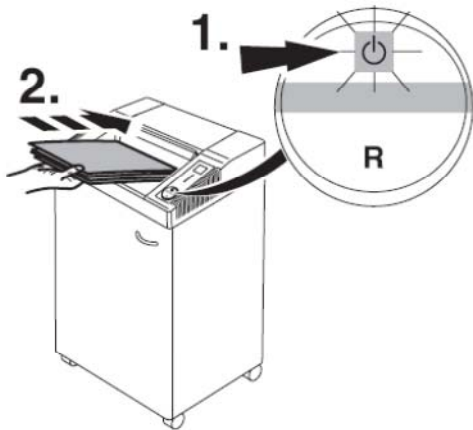

Is the rocker switch  pressed?
Is the green light rocker switch is ON? (1)
Insert paper (2).

For NATIONWIDE SERVICE Call 1(800)225-9293

TROUBLESHOOTING Cont....

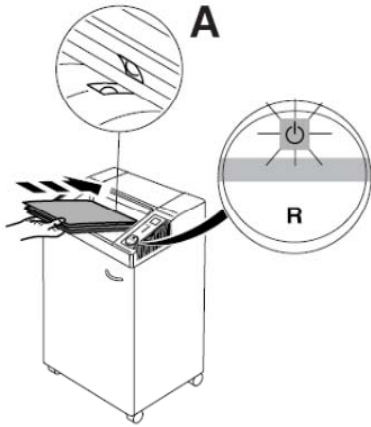

Feed the paper into the center of the feed opening.
(photo cell) (A)

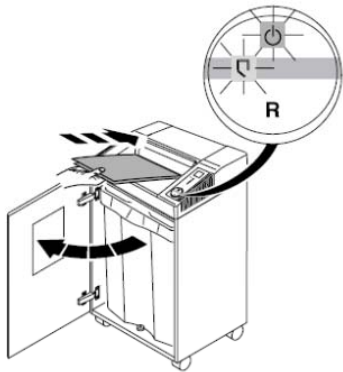

Is the door open?

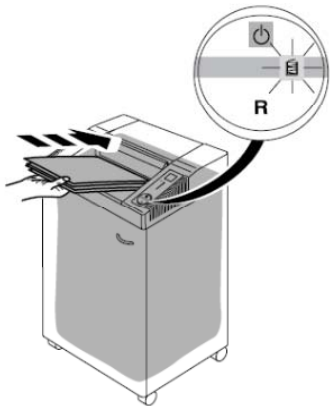

Is the bag full?

For NATIONWIDE SERVICE Call 1(800)225-9293

TROUBLESHOOTING Cont....

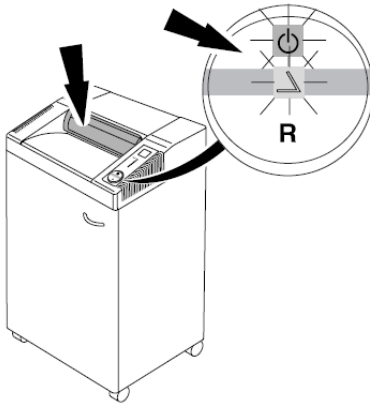

Is the safety flap open?

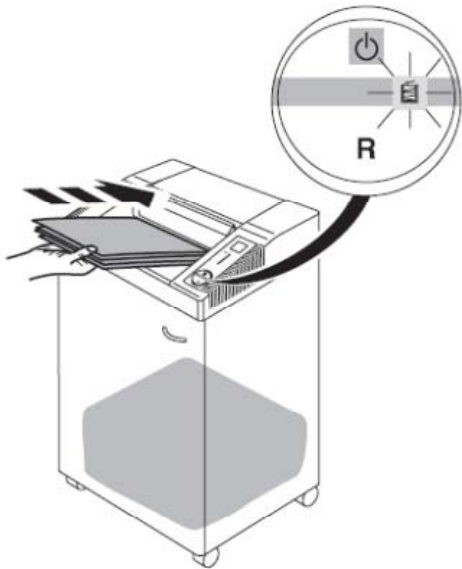

“Bag full” indicator  illuminates but bag is not full.

- Disconnect from the mains.
- Remove paper debris between the cutting head (A) and flap (B) with a brush. Picture shows the machine from underneath.

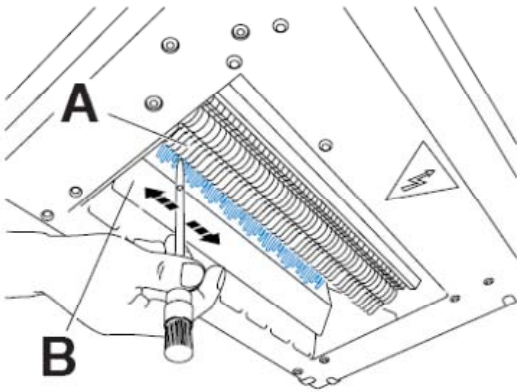

For NATIONWIDE SERVICE Call 1(800)225-9293

TROUBLESHOOTING Cont....

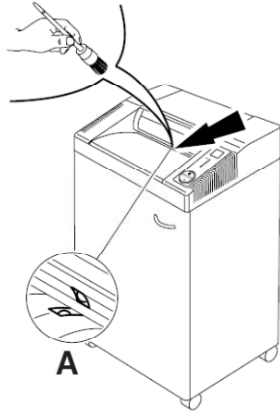

Machine will not stop.

Unplug from the main. Clean the photo cell (A) with a small brush or Q-tip with isopropyl (rubbing alcohol)

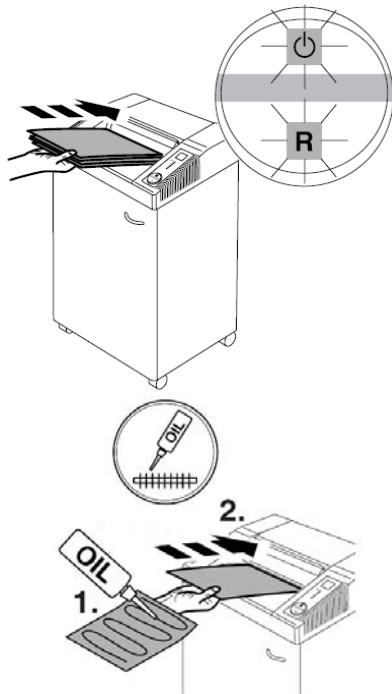

Machine stops.

Overload protection. **Cooling down period approximately 10-15 minutes.**

- Symbols ⏻ and "R" flash alternatively.
- Symbol ⏻ lights green, machine is ready for operation.

If the sheet capacity reduces or after the shred bin is emptied oil the shredding mechanism! (See picture)

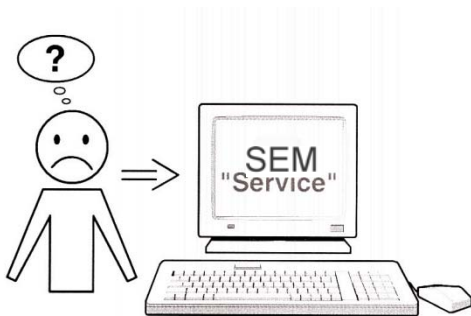

None of the above mentioned methods helped to solve the problem:

Contact our customer service at **1(800)225-9293**

For NATIONWIDE SERVICE Call 1(800)225-9293

ACCESSORIES

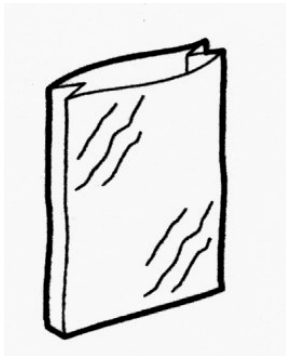

Plastic Bags (50 pieces)
Part # 640SB130A



Environmentally friendly oil (8 Pints)
Part # 649OIL8HV

For NATIONWIDE SERVICE Call 1(800)225-9293

TECHNICAL INFORMATION



Do not shred paper clips.
Do not destroy CD/DVD's.



This machine is approved by independent safety laboratories and is in compliance with the EC-regulations 98/37/EG, 2006/95/EG and 2004/108/EG.

Sound Level Information:

The sound level at the work place is less than the ISO 7779 standard' maximum permissible level of <70 db (A).



The exact technical specifications can be found on the technical specifications sticker on the machine.

To claim under guarantee, the machine must still carry its original identification label.



Subject to alterations without notice.



For NATIONWIDE SERVICE Call 1(800)225-9293

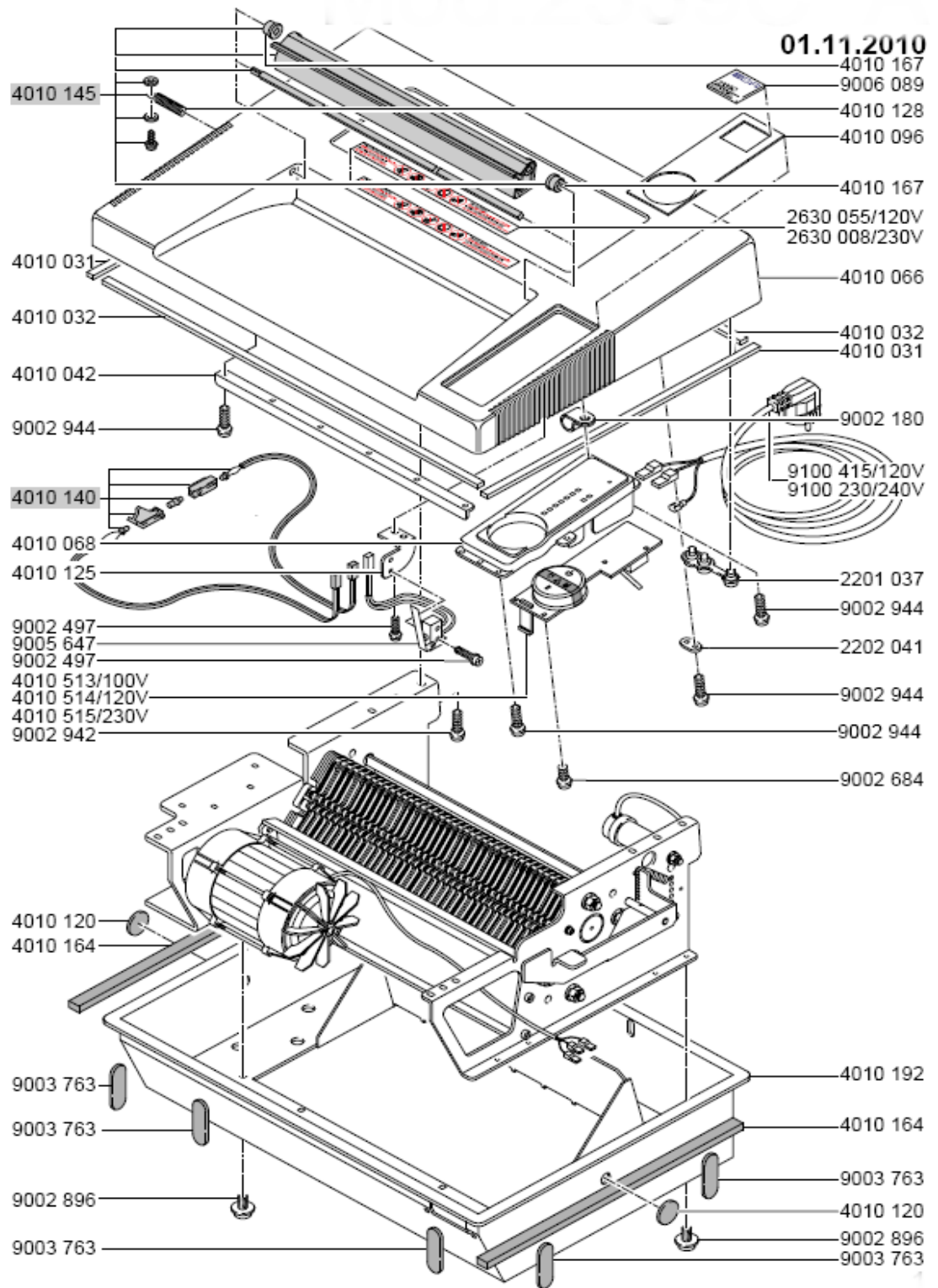

For NATIONWIDE SERVICE Call 1(800)225-9293

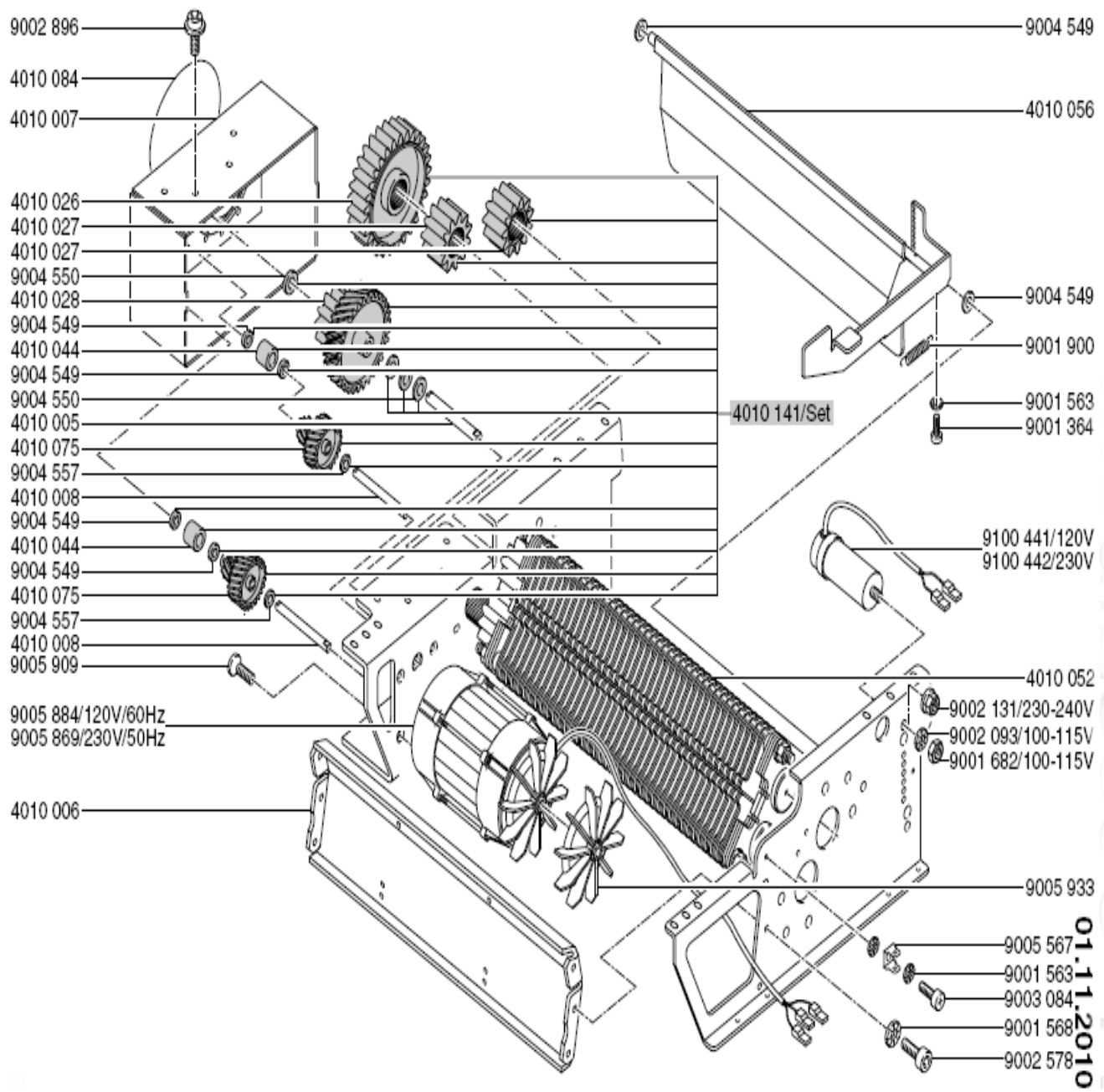

CROSS / CUT
 4x40mm
01.11.2010

For NATIONWIDE SERVICE Call 1(800)225-9293

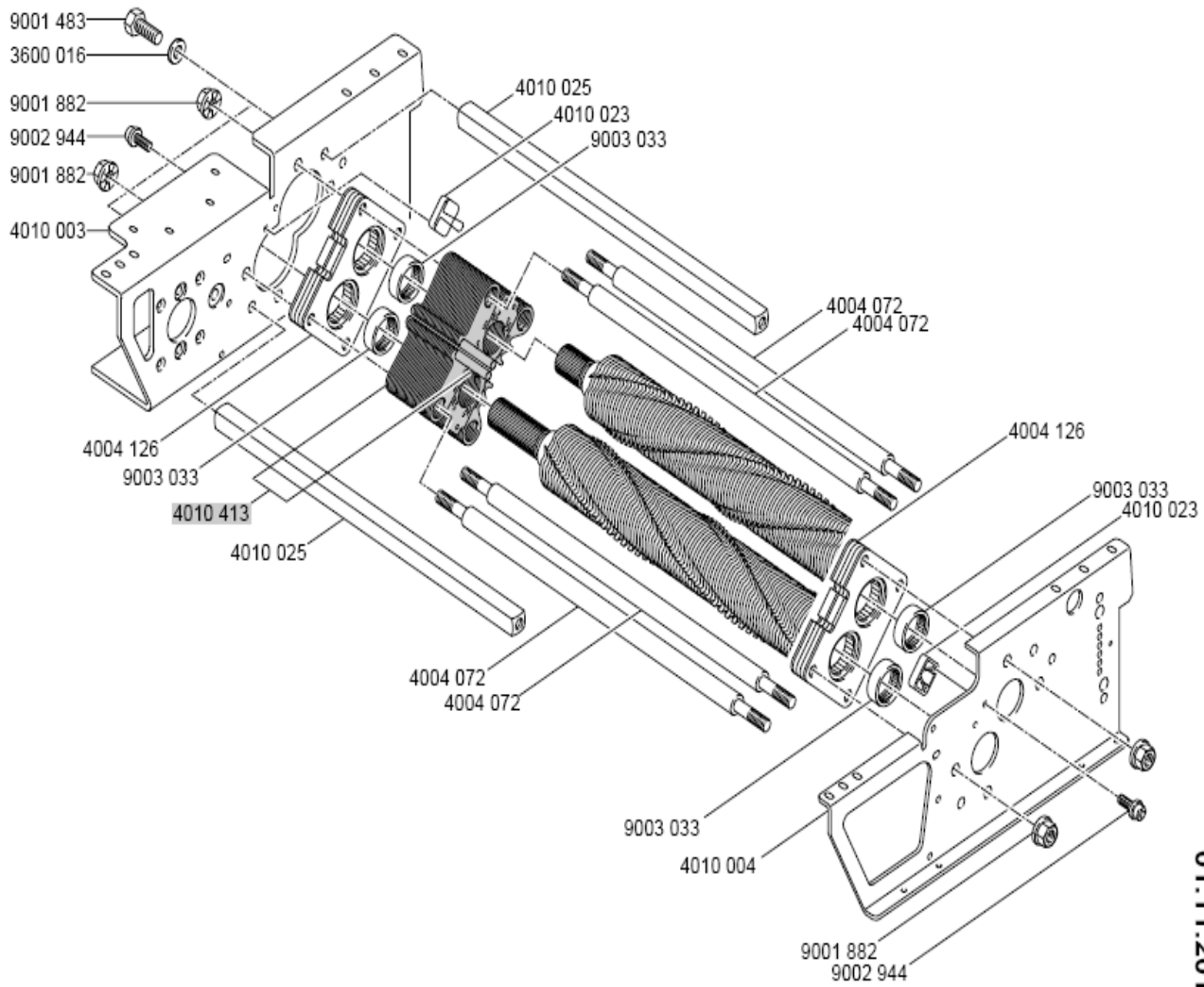

CROSS / CUT 4x40mm
01.11.2010

For NATIONWIDE SERVICE Call 1(800)225-9293

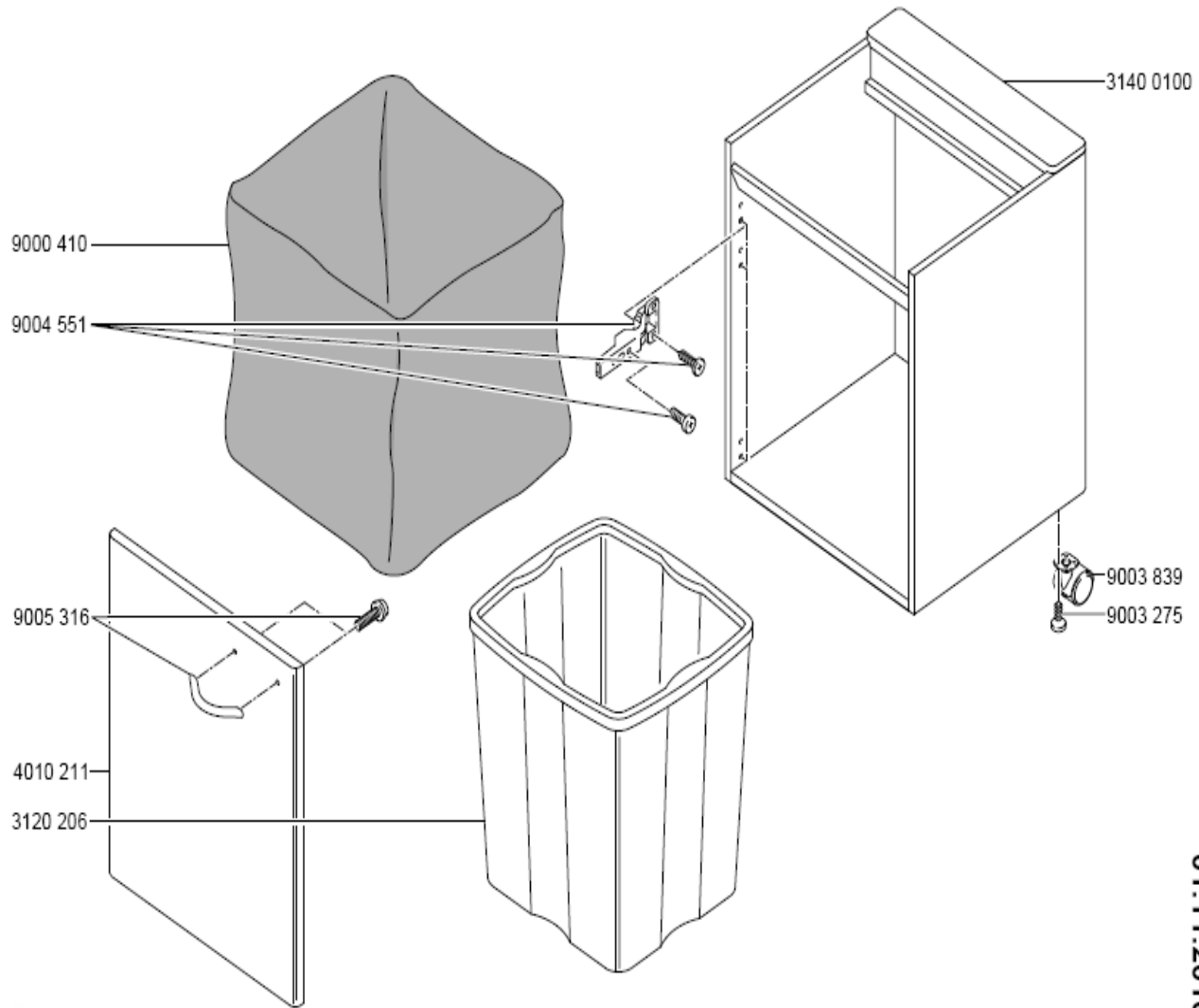

WMA 230000
CROSS / CUT 4x40mm
 01.11.2010

For NATIONWIDE SERVICE Call 1(800)225-9293

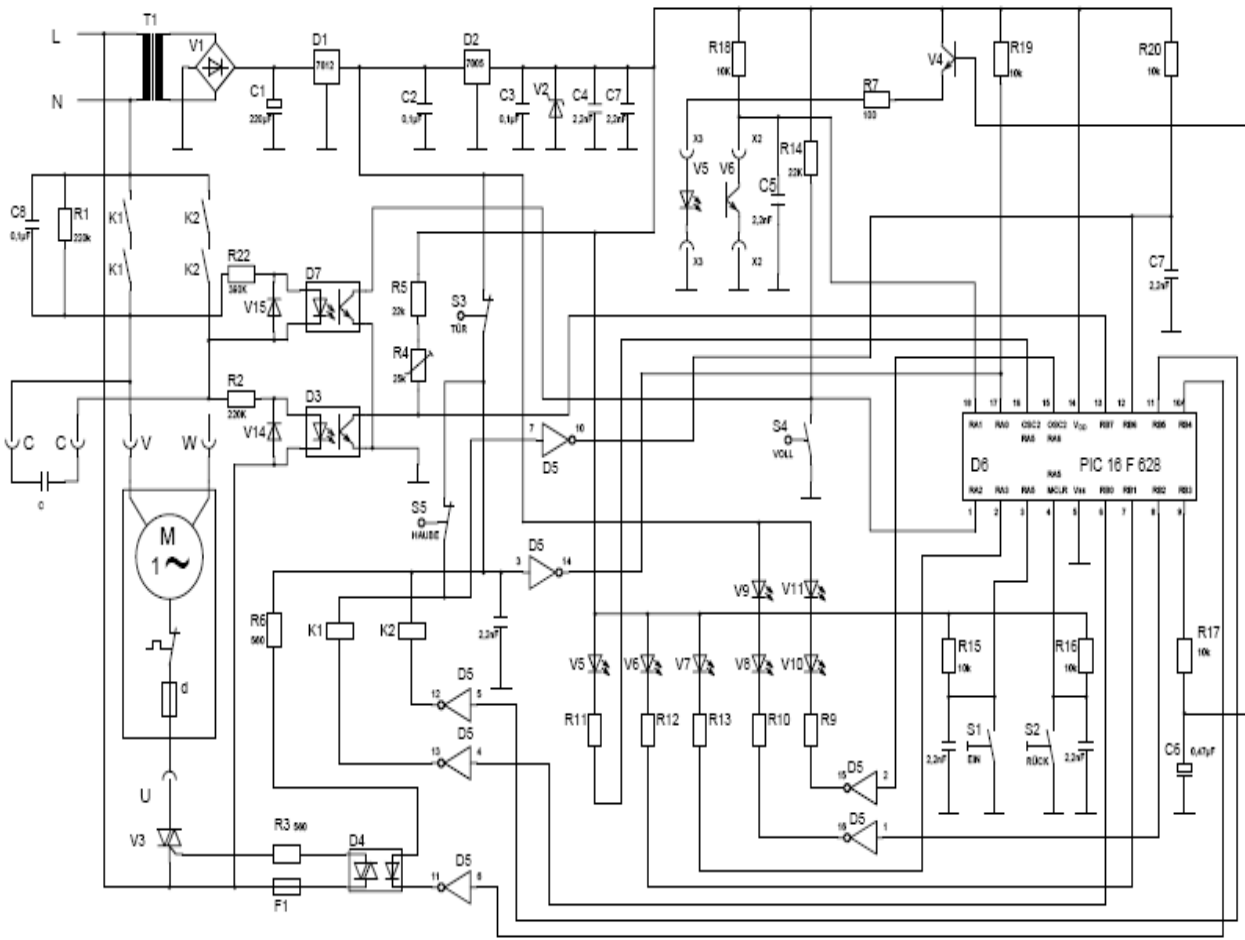

CROSS / CUT 4x40mm

01.11.2010

3810 236 wiring diagram

For NATIONWIDE SERVICE Call 1(800)225-9293

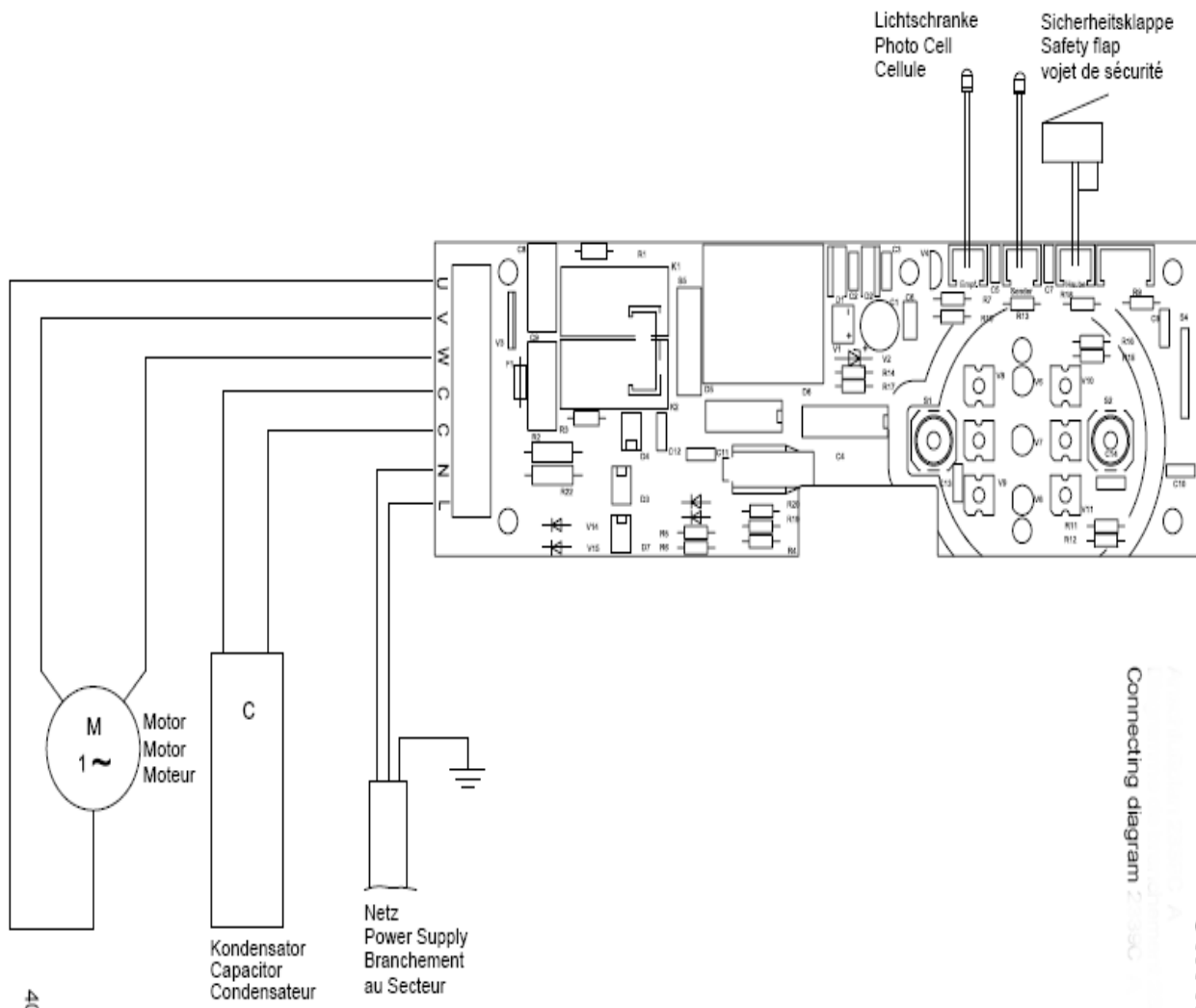

4010 511

CROSS / CUT 4x40mm
01.11.2010

For NATIONWIDE SERVICE Call 1(800)225-9293



Security Engineered Machinery Co., Inc. Product Information



Paper Shredders, Disintegrators/Industrial Shredders

Contract Number: GS-02F-0111P
 Contract Period: October 1, 2006 to September 30, 2011
 C3615 Shredders / Degaussers
 C3615 Accessories/Attachments for Shredders and Disintegrators
 C3615 Spare parts for Shredders and Disintegrators
 C3615 Disintegrators
 C3615 Remanufactured Disintegrators



**Paper Shredders • Disintegrators • Security Containers • Optical Media Declassifiers
 Shredding / Destruction Services**

For detail product information including all application and specifications, contact our Customer Service Department at 1-800-225-9293 or visit us on line at www.semshred.com for commercial customers and www.fedshred.com for government customers.